

# A superlinear bound on the number of perfect matchings in cubic bridgeless graphs

Louis Esperet\*    František Kardoš†    Daniel Král‡

## Abstract

Lovász and Plummer conjectured in the 1970's that cubic bridgeless graphs have exponentially many perfect matchings. This conjecture has been verified for bipartite graphs by Voorhoeve in 1979, and for planar graphs by Chudnovsky and Seymour in 2008, but in general only linear bounds are known. In this paper, we provide the first superlinear bound in the general case.

## 1 Introduction

In this paper we study cubic graphs in which parallel edges are allowed. A classical theorem of Petersen [10] asserts that every cubic bridgeless graph has a perfect matching. In fact, it holds that every edge of a cubic bridgeless graph is contained in a perfect matching. This implies that cubic bridgeless graphs have at least 3 perfect matchings. In the 1970's, Lovász and Plummer [7, Conjecture 8.1.8] conjectured that this quantity should grow exponentially with the number of vertices of a cubic bridgeless graph. The conjecture has been verified in some special cases: Voorhoeve [12] proved in 1979 that  $n$ -vertex cubic bridgeless bipartite graphs have

---

\*CNRS, Laboratoire G-SCOP, Grenoble, France. E-mail: [louis.esperet@g-scop.fr](mailto:louis.esperet@g-scop.fr). Partially supported by the European project IST FET AEOLUS.

†Institute of Mathematics, Faculty of Science, Pavol Jozef Šafárik University, Košice, Slovakia. E-mail: [frantisek.kardos@upjs.sk](mailto:frantisek.kardos@upjs.sk). Supported by Slovak Science and Technology Assistance Agency under contract No. APVV-0007-07.

‡Institute for Theoretical Computer Science, Faculty of Mathematics and Physics, Charles University, Prague, Czech Republic. E-mail: [kral@kam.mff.cuni.cz](mailto:kral@kam.mff.cuni.cz). Supported by The Czech Science Foundation under contract No. GACR 201/09/0197. The Institute for Theoretical Computer Science is supported by Ministry of Education of the Czech Republic as project 1M0545.

at least  $6 \cdot (4/3)^{n/2-3}$  perfect matchings. Recently, Chudnovsky and Seymour [1] proved that cubic bridgeless planar graphs with  $n$  vertices have at least  $2^{n/655978752}$  perfect matchings; Oum [9] proved that cubic bridgeless claw-free graphs with  $n$  vertices have at least  $2^{n/12}$  perfect matchings.

However, in the general case all known bounds are linear. Edmonds, Lovász, and Pulleyblank [3], inspired by Naddef [8], proved in 1982 that the dimension of the perfect matching polytope of a cubic bridgeless  $n$ -vertex graph is at least  $n/4 + 1$  which implies that these graphs have at least  $n/4 + 2$  perfect matchings. The bound on the dimension of the perfect matching polytope is best possible, but combining it with the study of the brick and brace decomposition of cubic graphs yielded improved bounds (on the number of perfect matchings in cubic bridgeless graphs) of  $n/2$  [5], and  $3n/4 - 10$  [4].

Our aim in this paper is to show that the number of perfect matchings in cubic bridgeless graphs is superlinear. More precisely, we prove the following theorem:

**Theorem 1.** *For any  $\alpha > 0$  there exists a constant  $\beta > 0$  such that every  $n$ -vertex cubic bridgeless graph has at least  $\alpha n - \beta$  perfect matchings.*

## 2 Notation

A graph  $G$  is  *$k$ -vertex-connected* if  $G$  has at least  $k+1$  vertices, and remains connected after removing any set of at most  $k-1$  vertices. If  $\{A, B\}$  is a partition of  $V(G)$ , the set  $E(A, B)$  of edges with one end in  $A$  and the other in  $B$  is called an *edge-cut* or a  *$k$ -edge-cut* of  $G$ , where  $k$  is the size of  $E(A, B)$ . A graph is  *$k$ -edge-connected* if it has no edge-cuts of size less than  $k$ . Finally, an edge-cut  $E(A, B)$  is *cyclic* if the subgraphs induced by  $A$  and  $B$  both contain a cycle. A graph  $G$  is *cyclically  $k$ -edge-connected* if  $G$  has no cyclic edge-cuts of size less than  $k$ . The following is a useful observation that we implicitly use in our further considerations:

**Observation 2.** *If  $G$  is a graph with minimum degree three, in particular  $G$  can be a cubic graph, then a  $k$ -edge-cut  $E(A, B)$  such that  $|A| \geq k-1$  and  $|B| \geq k-1$  must be cyclic.*

In particular, in a graph with minimum degree three, 2-edge-cuts are necessarily cyclic. Hence, 3-edge-connected cubic graphs and cyclically 3-edge-connected cubic graphs are the same.

We say that a graph  $G$  is  $X$ -near cubic for a multiset  $X$  of positive integers, if the multiset of degrees of  $G$  not equal to three is  $X$ . For example, the graph obtained from a cubic graph by removing an edge is  $\{2, 2\}$ -near cubic.

If  $v$  is a vertex of  $G$ , then  $G \setminus v$  is the graph obtained by removing the vertex  $v$  together with all its incident edges. If  $H$  is a connected subgraph of  $G$ ,  $G/H$  is the graph obtained by contracting all the vertices of  $H$  to a single vertex, removing arising loops and preserving all parallel edges. Let  $G$  and  $H$  be two disjoint cubic graphs,  $u$  a vertex of  $G$  incident with three edges  $e_1, e_2, e_3$ , and  $v$  a vertex of  $H$  incident with three edges  $f_1, f_2, f_3$ . Consider the graph obtained from the union of  $G \setminus u$  and  $H \setminus v$  by adding an edge between the end-vertices of  $e_i$  and  $f_i$  ( $1 \leq i \leq 3$ ) distinct from  $u$  and  $v$ . We say that this graph is obtained by *gluing*  $G$  and  $H$  through  $u$  and  $v$ . Note that gluing a graph  $G$  and  $K_4$  through a vertex  $v$  of  $G$  is the same as replacing  $v$  by a triangle.

A *Klee-graph* is inductively defined as being either  $K_4$ , or the graph obtained from a Klee-graph by replacing a vertex by a triangle. A  $b$ -*expansion* of a graph  $G$ ,  $b \geq 1$ , is obtained by gluing Klee-graphs with at most  $b + 1$  vertices each through some vertices of  $G$  (these vertices are then said to be *expanded*). For instance, a 3-expansion of  $G$  is a graph obtained by replacing some of the vertices of  $G$  with triangles, and by convention a 1-expansion is always the original graph. Observe that a  $b$ -expansion of a graph on  $n$  vertices has at most  $bn$  vertices. Also observe that if we consider  $k$  expanded vertices and contract their corresponding Klee-graphs into single vertices in the expansion, then the number of vertices decreases by at most  $k(b - 1) \leq kb$ .

Let  $G$  be a cyclically 4-edge-connected cubic graph and  $v_1v_2v_3v_4$  a path in  $G$ . The graph obtained by *splitting off* the path  $v_1v_2v_3v_4$  is the graph obtained from  $G$  by removing the vertices  $v_2$  and  $v_3$  and adding the edges  $v_1v_4$  and  $v'_1v'_4$  where  $v'_1$  is the neighbor of  $v_2$  different from  $v_1$  and  $v_3$ , and  $v'_4$  is the neighbor of  $v_3$  different from  $v_2$  and  $v_4$ .

**Lemma 3.** *Let  $G$  be a cyclically  $\ell$ -edge-connected graph with at least  $2\ell + 2$  vertices, let  $G'$  be the graph obtained from  $G$  by splitting off a path  $v_1v_2v_3v_4$ , and let  $v'_1$  be the neighbor of  $v_2$  different from  $v_1$  and  $v_3$ , and  $v'_4$  the neighbor of  $v_3$  different from  $v_2$  and  $v_4$ . If  $E(A', B')$  is a cyclic  $\ell'$ -edge-cut of  $G'$  with  $\ell' < \ell$ , then  $\ell' \geq \ell - 2$  and neither the edge  $v_1v_4$  nor the edge  $v'_1v'_4$  is contained in the cut  $E(A', B')$ .*

*Proof.* Assume first that the edges  $v_1v_4$  and  $v'_1v'_4$  are both in

the cut  $E(A', B')$ . If  $v_1, v_1 \in A'$  and  $v_4, v_4' \in B'$  then  $E(A' \cup \{v_2\}, B' \cup \{v_3\})$  is a cyclic  $(\ell - 1)$ -edge-cut of  $G$ . Otherwise if  $v_1, v_4' \in A'$  and  $v_4, v_1' \in B'$  then  $E(A' \cup \{v_2, v_3\}, B')$  is a cyclic  $\ell'$ -edge-cut of  $G$ . Since  $G$  is cyclically  $\ell$ -edge-connected, we can exclude these cases.

Assume now that only  $v_1 v_4$  is contained in the cut, i.e.,  $v_1 \in A'$  and  $v_4 \in B'$  by symmetry. We can also assume by symmetry that  $v_1'$  and  $v_4'$  are in  $A'$ . However in this case, the cut  $E(A' \cup \{v_2, v_3\}, B')$  is a cyclic  $\ell'$ -edge-cut of  $G$  which is impossible. Hence, neither  $v_1 v_4$  nor  $v_1' v_4'$  is contained in the cut. Similarly, if  $\{v_1, v_1', v_4, v_4'\} \subseteq A'$  or  $\{v_1, v_1', v_4, v_4'\} \subseteq B'$ , then  $G$  would contain a cyclic  $\ell'$ -edge-cut.

We conclude that it can be assumed that  $\{v_1, v_4\} \subseteq A'$ ,  $\{v_1', v_4'\} \subseteq B'$ , and  $|A'| \leq |B'|$ . Say  $A := A' \cup \{v_2, v_3\}$ ,  $B := B'$ . Since  $G'[A']$  has a cycle,  $G[A]$  has a cycle, too. Since  $|B| \geq \ell$ , there is a cycle in  $G[B]$  as well. Therefore,  $E(A, B)$  is a cyclic  $(\ell + 2)$ -edge-cut in  $G$  and thus  $\ell'$  is either  $\ell - 2$  or  $\ell - 1$ .  $\square$

A cubic graph  $G$  is *k-almost cyclically  $\ell$ -edge-connected* if there is a cyclically  $\ell$ -edge-connected cubic graph  $G'$  obtained from  $G$  by contracting sides of none, one or more cyclic 3-edge-cuts and the number of vertices of  $G'$  is at least the number of vertices of  $G$  decreased by  $k$ . In particular, a graph  $G$  is 2-almost cyclically 4-edge-connected graph if and only if  $G$  is cyclically 4-edge-connected or  $G$  contains a triangle such that the graph obtained from  $G$  by replacing the triangle with a vertex is cyclically 4-edge-connected. Observe that the perfect matchings of the cyclically 4-edge-connected cubic graph  $G'$  correspond to perfect matchings of  $G$  (but several perfect matchings of  $G$  can correspond to the same perfect matching of  $G'$  and some perfect matchings of  $G$  correspond to no perfect matching of  $G'$ ).

We now list a certain number of facts related to perfect matchings in graphs, that will be used several times in the proof. The first one, due to Kotzig, concerns graphs (not necessarily cubic) with only one perfect matching.

**Lemma 4.** *If  $G$  is a graph with a unique perfect matching, then  $G$  has a bridge that is contained in the unique perfect matching of  $G$ .*

A graph  $G$  is said to be *matching-covered* if every edge is contained in a perfect matching of  $G$ , and it is *double covered* if every edge is contained in at least two perfect matchings of  $G$ .

**Theorem 5** ([11]). *Every cubic bridgeless graph is matching-covered. Moreover, for any two edges  $e$  and  $f$  of  $G$ , there is a perfect matching avoiding both  $e$  and  $f$ .*

The following three theorems give lower bounds on the number of perfect matchings in cubic graphs.

**Theorem 6** ([1]). *Every planar cubic graph (and thus every Klee-graph) with  $n$  vertices has at least  $2^{n/655978752}$  perfect matchings.*

**Theorem 7** ([12]). *Every cubic bridgeless bipartite graph with  $n$  vertices has at least  $(4/3)^{n/2}$  perfect matchings avoiding any given edge.*

**Theorem 8** ([5]). *Every cubic bridgeless graph with  $n$  vertices has at least  $n/2$  perfect matchings.*

The main idea in the proof of Theorem 1 will be to cut the graph into pieces, apply induction, and try to combine the perfect matchings in the different parts. If they do not combine well then we will show that Theorems 6 and 7 can be applied to large parts of the graphs to get the desired result. Typically this will happen if some part is not double covered (some edge is in only one perfect matching), or if no perfect matching contains a given edge while excluding another one. In these cases the following two lemmas will be very useful.

**Lemma 9** ([4]). *Every cyclically 3-edge-connected cubic graph that is a not a Klee-graph is double covered. In particular, every cyclically 4-edge-connected cubic graph is double covered.*

**Lemma 10** ([4]). *Let  $G$  be a cyclically 4-edge-connected cubic graph and  $e$  and  $f$  two edges of  $G$ .  $G$  contains no perfect matchings avoiding  $e$  and containing  $f$  if and only if the graph  $G \setminus \{e, f\}$  is bipartite and the end-vertices of  $e$  are in one color class while and the end-vertices of  $f$  are in the other.*

The key to prove Theorem 1 is to show by induction that cyclically 4-edge-connected cubic graphs have a superlinear number of perfect matchings avoiding any given edge. In the proof we need to pay special attention to 3-edge-connected graphs, because we were unable to include them in the general induction process. The next section, which might be of independent interest for the reader, will be devoted to the proof of Lemma 18, stating that 3-edge-connected cubic graphs have a linear number of perfect matchings avoiding any given edge that is not contained in a cyclic 3-edge-cut (this assumption on the edge cannot be dropped).

### 3 3-edge-connected graphs

We now introduce the *brick and brace decomposition* of matching-covered graphs (which will only be used in this section). For a simple graph  $G$ , we call a *multiple of  $G$*  any multigraph whose underlying simple graph is isomorphic to  $G$ .

An edge-cut  $E(A, B)$  is *tight* if every perfect matching contains precisely one edge of  $E(A, B)$ . If  $G$  is a connected matching-covered graph with a tight edge-cut  $E(A, B)$ , then  $G[A]$  and  $G[B]$  are also connected. Moreover, every perfect matching of  $G$  corresponds to a pair of perfect matchings in the graphs  $G/A$  and  $G/B$ . Hence, both  $G/A$  and  $G/B$  are also matching-covered. We say that we have decomposed  $G$  into  $G/A$  and  $G/B$ . If any of these graphs still have a tight edge-cut, we can keep decomposing it until no graph in the decomposition has a tight edge-cut. Matching-covered graphs without tight edge-cuts are called *braces* if they are bipartite and *bricks* otherwise, and the decomposition of a graph  $G$  obtained this way is known as the *brick and brace decomposition of  $G$* .

Lovász [6] showed that the collection of graphs obtained from  $G$  in any brick and brace decomposition is unique up to the multiplicity of edges. This allows us to speak of *the* brick and brace decomposition of  $G$ , as well as *the* number of bricks (denoted  $b(G)$ ) and *the* number of braces in the decomposition of  $G$ . The brick and brace decomposition has the following interesting connection with the number of perfect matchings:

**Theorem 11** (Edmonds *et al.*, 1982). *If  $G$  is a matching-covered  $n$ -vertex graph with  $m$  edges, then  $G$  has at least  $m - n + 1 - b(G)$  perfect matchings.*

A graph is said to be *bicritical* if  $G \setminus \{u, v\}$  has a perfect matching for any two vertices  $u$  and  $v$ . Edmonds *et al.* [3] gave the following characterization of bricks:

**Theorem 12** (Edmonds *et al.*, 1982). *A graph  $G$  is a brick if and only if it is 3-vertex-connected and bicritical.*

It can also be proved that a brace is a bipartite graph such that for any two vertices  $u$  and  $u'$  from the same color class and any two vertices  $v$  and  $v'$  from the other color class, the graph  $G \setminus \{u, u', v, v'\}$  has a perfect matching, see [7]. We finish this brief introduction to the brick and brace decomposition with two lemmas on the number of bricks in some particular classes of graphs.

**Lemma 13** (see [5]). *If  $G$  is an  $n$ -vertex cubic bridgeless graph, then  $b(G) \leq n/4$ .*

**Lemma 14** (see [4]). *If  $G$  is a bipartite matching-covered graph, then  $b(G) = 0$ .*

We now show that any 3-edge-connected cubic graph  $G$  has a linear number of perfect matchings avoiding any edge  $e$  not contained in a cyclic 3-edge-cut. We consider two cases: if  $G - e$  is matching-covered, we show that its decomposition contains few bricks (Lemma 15). If  $G - e$  is not matching-covered, we show that for some edge  $f$ ,  $G - \{e, f\}$  is matching-covered and contains few bricks in its decomposition (Lemma 17).

**Lemma 15.** *Let  $G$  be a 3-edge-connected cubic graph and  $e$  an edge of  $G$  that is not contained in a cyclic 3-edge-cut of  $G$ . If  $G - e$  is matching-covered, then the number of bricks in the brick and brace decomposition of  $G - e$  is at most  $3n/8 - 2$ .*

*Proof.* Let  $u$  and  $v$  be the end-vertices of  $e$ . Clearly, the edges between  $\{u\} \cup N(u)$  and the other vertices and the edges between  $\{v\} \cup N(v)$  and the other vertices form tight edge-cuts in  $G - e$ . Splitting along these tight edge-cuts, we obtain two multiples of  $C_4$  and a graph  $G'$  with  $n - 4$  vertices. Depending whether  $u$  and  $v$  are in a triangle in  $G$ ,  $G'$  is either a  $\{4, 4\}$ -near cubic graph or a  $\{5\}$ -near cubic graph.

We will now keep splitting  $G'$  along tight edge-cuts until we obtain bricks and braces only. We show that any graph  $H$  obtained during splitting will be 3-edge-connected and it will be either a bipartite graph, a cubic graph, a  $\{4, 4\}$ -near cubic graph or a  $\{5\}$ -near cubic graph. Moreover, the edge  $e$  will correspond in a  $\{4, 4\}$ -near cubic graph to an edge joining the two vertices of degree four in  $H$ , and it will correspond in a  $\{5\}$ -near cubic graph to a loop incident with the vertex of degree five.

If  $H$  is a  $\{4, 4\}$ -near cubic graph and the two vertices  $u$  and  $v$  of degree four have two common neighbors that are adjacent, we say that  $H$  contains a *4-diamond* with end-vertices  $u$  and  $v$  (see the first picture of Figure 1 for the example of a 4-diamond with end-vertices  $v$  and  $w$ ). After we construct the decomposition, we prove the following estimate on the number of bricks in the brick and brace decomposition of  $H$ :

*Claim.* *Assume that  $H$  is not a multiple of  $K_4$ , and that it has  $n_H$  vertices. Then  $b(H) \leq \frac{3}{8} n_H - 1$  if  $H$  is cubic,  $b(H) \leq \frac{3}{8} n_H - \frac{3}{4}$  if  $H$  is a  $\{5\}$ -near cubic graph or a  $\{4, 4\}$ -near cubic graph without 4-diamond, and  $b(H) \leq \frac{3}{8} n_H - \frac{1}{4}$  if  $H$  contains a 4-diamond.*

Observe that the claim implies that if  $H$  has no 4-diamond,  $b(H) \leq \frac{3}{8}n_H - \frac{1}{2}$  regardless whether  $H$  is a multiple of  $K_4$  or not. To simplify our exposition, we consider the construction of the decomposition and after each step, we assume that we have verified the claim on the number of bricks for the resulting graphs and verify it for the original one.

Let  $H$  be a graph obtained through splitting along tight edge-cuts, initially  $H = G'$ . Observe that  $G'$  is 3-edge-connected since the edge  $e$  is not contained in any cyclic 3-edge-cut of  $G$ .

If  $H$  is bipartite, from Lemma 14 we get  $b(H) = 0$ .

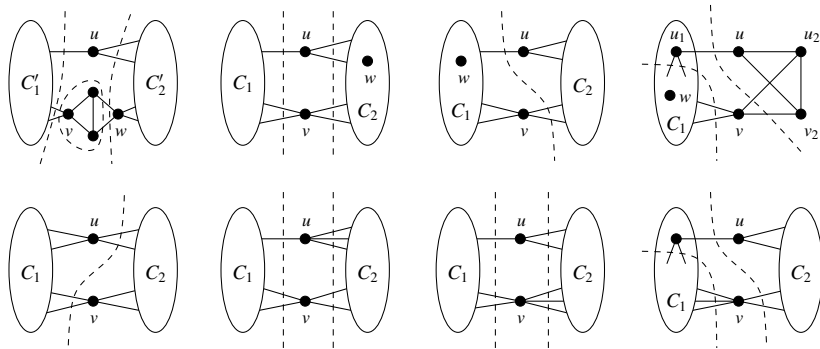

Figure 1: Some cases if  $H$  has a 2-vertex-cut  $\{u, v\}$ . The tight edge-cuts are represented by dashed lines.

If  $H$  is not bipartite, then by Theorem 12 it is a brick unless it is not 3-vertex-connected or it is not bicritical. If it is a brick then the inequalities of the claim are satisfied since  $n_H \geq 6$  unless  $H$  is a multiple of  $K_4$ . Assume now that  $H$  is not 3-vertex-connected. By the induction, the maximum degree of  $H$  is at most five and since  $H$  is 3-edge-connected, it cannot contain a cut-vertex. Let  $\{u, v\}$  be a 2-vertex-cut of  $H$ . Since the sum of the degrees of  $u$  and  $v$  is at most eight, the number of components of  $H \setminus \{u, v\}$  is at most two. Let  $C_1$  and  $C_2$  be the two components of  $H \setminus \{u, v\}$ . We now distinguish several cases based on the degrees of  $u$  and  $v$  (symmetric cases are omitted):

$d_H(u) = d_H(v) = 3$ . It is easy to verify that  $H$  cannot be 3-edge-connected.

$d_H(u) = 3, d_H(v) = 4, uv \in E(H)$ . It is again easy to verify that  $H$  cannot be 3-edge-connected.

$d_H(u) = 3, d_H(v) = 4, uv \notin E(H)$ . Since  $H$  is 3-edge-connected, there must be exactly two edges between  $v$  and each  $C_i, i = 1, 2$ . By symmetry, we can assume that there a single edge between  $u$  and  $C_1$  and two edges between  $u$  and  $C_2$ .

Let  $w$  be the other vertex of  $H$  with degree four. Assume first that  $v$  and  $w$  are the end-points of a 4-diamond (this case is depicted in the first picture of Figure 1). Let  $C'_1$  and  $C'_2$  be the two components remaining in  $H$  after removing  $u$  and the four vertices of the 4-diamond. Without loss of generality, assume that the two neighbors of  $v$  (resp.  $w$ ) not in the diamond are in  $C'_1$  (resp.  $C'_2$ ). We split  $H$  along the three following tight edge-cuts: the three edges leaving  $C'_1$ , the four edges leaving  $C'_2 \cup \{w\}$ , and finally the four edges leaving  $v$  and its two neighbors in the 4-diamond. We obtain a cubic graph  $H_1$ , a multiple of  $K_4$ , a multiple of  $C_4$ , and a  $\{4, 4\}$ -near cubic graph  $H_2$ . If  $n_1$  and  $n_2$  are the orders of  $H_1$  and  $H_2$ , we have  $n_1 + n_2 = n_H - 2$ . By the induction,

$$b(H) \leq 1 + \left(\frac{3}{8}n_1 - \frac{1}{2}\right) + \left(\frac{3}{8}n_2 - \frac{1}{4}\right) = \frac{3}{8}n_H - \frac{1}{2} \leq \frac{3}{8}n_H - \frac{1}{4}.$$

Hence, we can assume that  $H$  does not contain a 4-diamond. If  $w$  is contained in  $C_2$ , both  $C_1$  and  $C_2$  have an odd number of vertices and both the cuts between  $\{u, v\}$  and  $C_i, i = 1, 2$ , are tight (this case is depicted in the second picture of Figure 1). After splitting along them, we obtain a multiple of  $C_4$ , a cubic graph of order  $n_1$  and a  $\{4, 4\}$ -near cubic graph of order  $n_2$ , such that  $n_1 + n_2 = n_H$ . By the induction,

$$b(H) \leq \frac{3}{8}n_H - \frac{1}{2} - \frac{1}{4} = \frac{3}{8}n_H - \frac{3}{4}.$$

It remains to analyse the case when  $w$  is contained in  $C_1$  (this case is depicted in the third picture of Figure 1). Splitting the graph along the tight edge-cut between  $C_1 \cup \{v\}$  and  $C_2 \cup \{u\}$ , we obtain a  $\{4, 4\}$ -near cubic graph  $H_1$  which is not a multiple of  $K_4$  (otherwise  $u$  would have more than one neighbor in  $C_1$ ), and a cubic graph  $H_2$ . Observe that  $H_1$  does not contain any 4-diamond, since otherwise  $H$  would contain one. If  $H_2$  is not a multiple of  $K_4$ , then by the induction  $b(H) \leq \frac{3}{8}(n_H + 2) - \frac{3}{4} - 1 \leq \frac{3}{8}n_H - \frac{3}{4}$ . Assume now that  $H_2$  is a

multiple of  $K_4$ , and let  $u_1$  be the neighbor of  $u$  in  $C_1$ , and  $u_2$  and  $v_2$  be the vertices of  $C_2$  (this case is depicted in the fourth picture of Figure 1). We split  $H$  along the two following tight edge-cuts: the edges leaving  $\{u, u_2, v_2\}$ , and the edges leaving  $\{u_1, u, v, u_2, v_2\}$ . We obtain a multiple of  $K_4$ , a multiple of  $C_4$ , and a graph of order  $n_H - 4$ , which is either a  $\{4, 4\}$ -near cubic graph or a  $\{5\}$ -near cubic graph (depending whether  $u_1 = w$ ). In any case

$$b(H) \leq 1 + \frac{3}{8}(n_H - 4) - \frac{1}{4} = \frac{3}{8}n_H - \frac{3}{4}.$$

**$d_H(u) = d_H(v) = 4, uv \in E(H)$ .** The sizes of  $C_1$  and  $C_2$  must be even; otherwise, there is no perfect matching containing the edge  $uv$ . Hence, the number of edges between  $\{u, v\}$  and  $C_i$  is even and one of these cuts has size two, which is impossible since  $H$  is 3-edge-connected.

**$d_H(u) = d_H(v) = 4, uv \notin E(H)$ .** Assume first that there are exactly two edges between each of the vertices  $u$  and  $v$  and each of the components  $C_i$  (this case is depicted in the fifth picture of Figure 1). In this case, each  $C_i$  must contain an even number of vertices. Hence, the edges between  $C_1 \cup \{u\}$  and  $C_2 \cup \{v\}$  form a tight edge-cut. Let  $H_1$  and  $H_2$  be the two graphs obtained by splitting along this tight edge-cut. Observe that if  $H$  contains a 4-diamond, then at least one of  $H_1$  and  $H_2$  is a multiple of  $K_4$ . Moreover,  $H_i$  contains a 4-diamond if and only if it is a multiple of  $K_4$ . Consequently, if neither  $H_1$  nor  $H_2$  is a multiple of  $K_4$ , then none of  $H, H_1$ , and  $H_2$  contains a 4-diamond. Hence by the induction,  $b(H) \leq \frac{3}{8}(n_H + 2) - \frac{3}{4} - \frac{3}{4} = \frac{3}{8}n_H - \frac{3}{4}$ . If both  $H_1$  and  $H_2$  are multiples of  $K_4$ , then  $H$  has  $2 = \frac{3}{8} \times 6 - \frac{1}{4}$  bricks. Finally if exactly one of  $H_1$  and  $H_2$ , say  $H_2$ , is a multiple of  $K_4$ , then  $H$  contains a 4-diamond and  $H_1$  does not. Hence,

$$b(H) \leq 1 + \frac{3}{8}(n_H - 2) - \frac{3}{4} \leq \frac{3}{8}n_H - \frac{1}{4}.$$

If there are not exactly two edges between each of the vertices  $u$  and  $v$  and each of the components  $C_i$ , then we can assume that there is one edge between  $u$  and  $C_1$  and three edges between  $v$  and  $C_2$  (this case is depicted in the sixth picture of Figure 1). Since  $H$  is 3-edge-connected, there are exactly two edges between  $v$  and each of the components  $C_i$ ,  $i = 1, 2$ . Observe that each  $C_i$  contains an odd number of vertices and thus the cuts between  $C_i$  and  $\{u, v\}$  are tight. Splitting the graph along these tight edge-cuts, we obtain a multiple of  $C_4$ , a cubic graph

$H_1$ , and a  $\{5\}$ -near cubic graph  $H_2$ , of orders  $n_1$  and  $n_2$  satisfying  $n_1 + n_2 = n_H$ . By the induction,

$$b(H) \leq \frac{3}{8}n_1 - \frac{1}{2} + \frac{3}{8}n_2 - \frac{1}{2} \leq \frac{3}{8}n_H - \frac{3}{4}.$$

$d_H(u) = 3, d_H(v) = 5, uv \in E(H)$ . Since  $H$  is 3-edge-connected, the number of edges between  $u$  and each  $C_i$  is one and between  $v$  and each  $C_i$  is two. Hence, both  $C_1$  and  $C_2$  contain an odd number of vertices and thus there is no perfect matching containing the edge  $uv$  which is impossible since  $H$  is matching-covered.

$d_H(u) = 3, d_H(v) = 5, uv \notin E(H)$ . By symmetry, we can assume that there is one edge between  $C_1$  and  $u$  and two edges between  $C_2$  and  $v$ . We have to distinguish two cases: there are either two or three edges between  $C_1$  and  $v$  (other cases are excluded by the fact that  $H$  is 3-edge-connected).

If there are two edges between  $C_1$  and  $v$ , the number of vertices of both  $C_1$  and  $C_2$  is odd (this case is depicted in the seventh picture of Figure 1). Hence, both the edge-cuts between  $C_i, i = 1, 2$ , and  $\{u, v\}$  are tight. The graphs obtained by splitting along these two edge-cuts are a multiple of  $C_4$ , a cubic graph  $H_1$ , and a  $\{5\}$ -near cubic graph  $H_2$ , of orders  $n_1$  and  $n_2$  satisfying  $n_1 + n_2 = n_H$ . By the induction,

$$b(H) \leq \frac{3}{8}n_1 - \frac{1}{2} + \frac{3}{8}n_2 - \frac{1}{2} \leq \frac{3}{8}n_H - \frac{3}{4}.$$

If there are three edges between  $C_1$  and  $v$ , the edge-cut between  $C_1 \cup \{v\}$  and  $C_2 \cup \{u\}$  is tight (this case is depicted in the seventh and last picture of Figure 1). Splitting along this edge-cut, we obtain a  $\{5\}$ -near cubic graph  $H_1$  which is not a multiple of  $K_4$  (the underlying simple graph has a vertex of degree two), and a cubic graph  $H_2$ , of orders  $n_1$  and  $n_2$  satisfying  $n_1 + n_2 = n_H + 2$ . Let  $u'$  be the new vertex of  $H_1$  and let  $u_1$  be its neighbor in  $C_1$ . Observe that the edges leaving  $\{u', u_1, v\}$  form a tight edge-cut in  $H_1$ . Splitting along it we obtain a  $\{5\}$ -near cubic graph  $H'_1$  of order  $n_1 - 2$  and a multiple of  $C_4$ . Hence, by induction,

$$b(H) \leq \frac{3}{8}(n_1 - 2) - \frac{1}{2} + \frac{3}{8}n_2 - \frac{1}{2} \leq \frac{3}{8}n_H - \frac{3}{4}.$$

It remains to analyse the case when  $H$  is 3-vertex-connected but not bicritical. Let  $u$  and  $u'$  be two vertices of  $H$  such that  $H \setminus \{u, u'\}$  has no

perfect matching. Hence, there exists a subset  $S$  of vertices of  $H$ ,  $\{u, u'\} \subseteq S$ ,  $|S| = k \geq 3$ , such that the number of odd components of  $H \setminus S$  is at least  $k - 1$ . Since the order of  $H$  is even, the number of odd components of  $H \setminus S$  is at least  $k$ . An argument based on counting the degrees of vertices yields that there are exactly  $k$  components of  $G \setminus S$ ; let  $C_1, \dots, C_k$  be these components. Clearly, for each  $i = 1, \dots, k$  the cut between the component  $C_i$  and the set  $S$  is a tight edge-cut. Let  $H_i$  be the graph containing  $C_i$  obtained by splitting the cut; let  $H_0$  be the graph containing vertices from  $S$  obtained after splitting all these cuts. Let  $n_i$  be the order of  $H_i$ . Clearly,  $n_0 = 2k$  and  $\sum_{i=1}^k n_i = n_H$ . An easy counting argument yields that the number of edges joining  $S$  and  $H \setminus S$  is between  $3k$  and  $3k + 2$ , hence, all the graphs  $H_i$  ( $i = 0, \dots, k$ ) are cubic,  $\{4, 4\}$ -near cubic or  $\{5\}$ -near cubic. However, at most two graphs  $H_i$  are  $\{4, 4\}$ -near cubic (or one is  $\{5\}$ -near cubic).

If  $H_0$  is bipartite, then  $b(H_0) = 0$  and applying the induction to each  $H_i$ , we obtain that  $H$  has at most

$$\frac{3}{8}(n_1 + \dots + n_k) - (k - 2) \cdot \frac{1}{2} - 2 \cdot \frac{1}{4} = \frac{3}{8}n_H - \frac{1}{2}(k - 1)$$

bricks. Since  $k \geq 3$ , we have  $b(H) \leq \frac{3}{8}n_H - 1$ .

If  $H_0$  is not bipartite, then all the  $k$  tight edge-cuts are 3-edge-cuts, moreover,  $H_0$  is a  $\{4, 4\}$ -near cubic or  $\{5\}$ -near cubic graph and all the graphs  $H_i$  ( $i = 1, \dots, k$ ) are cubic. Applying the induction to each  $H_i$  (including  $H_0$ ), we obtain that  $H$  has at most

$$\frac{3}{8}(n_0 + n_1 + \dots + n_k) - k \cdot 1 - \frac{1}{4} = \frac{3}{8}n_H - \frac{1}{4}(k + 1)$$

bricks. Since  $k \geq 3$ , we have  $b(H) \leq \frac{3}{8}n_H - 1$ , which finishes the proof of the claim.

As a consequence, using that  $G'$  has  $n - 4$  vertices, we obtain that the brick and brace decomposition of  $G - e$  contains at most  $\frac{3}{8}(n - 4) - \frac{1}{4} = \frac{3}{8}n - 2$  bricks. Note that we made sure throughout the proof, by induction, that all the graphs obtained by splitting cuts are 3-edge-connected and are either bipartite, cubic,  $\{4, 4\}$ -near cubic, or  $\{5\}$ -near cubic.  $\square$

We now consider the case that  $G - e$  is not matching-covered. Before proving Lemma 17, we will introduce the perfect matching polytope of graphs.

The *perfect matching polytope* of a graph  $G$  is the convex hull of characteristic vectors of perfect matchings of  $G$ . The sufficient and necessary

conditions for a vector  $w \in \mathbb{R}^{E(G)}$  to lie in the perfect matching polytope are known [2]:

**Theorem 16** (Edmonds, 1965). *If  $G$  is a graph, then a vector  $w \in \mathbb{R}^{E(G)}$  lies in the perfect matching polytope of  $G$  if and only if the following holds:*

- (i)  $w$  is non-negative,
- (ii) for every vertex  $v$  of  $G$  the sum of the entries of  $w$  corresponding to the edges incident with  $v$  is equal to one, and
- (iii) for every set  $S \subseteq V(G)$ ,  $|S|$  odd, the sum of the entries corresponding to edges having exactly one vertex in  $S$  is at least one.

It is also well-known that conditions (i) and (ii) are necessary and sufficient for a vector to lie in the perfect matching polytope of a bipartite graph  $G$ .

We now use these notions to prove the following result:

**Lemma 17.** *Let  $G$  be a 3-edge-connected cubic graph  $G$  and  $e$  an edge of  $G$  such that  $e$  is not contained in any cyclic 3-edge-cut of  $G$ . If  $G - e$  is not matching-covered, then there exists an edge  $f$  of  $G$  such that  $G - \{e, f\}$  is matching-covered and the number of bricks in the brick and brace decomposition of  $G - \{e, f\}$  is at most  $n/4 - 1$ .*

*Proof.* Since  $G$  is not matching-covered, there exists an edge  $f$  that is contained in no perfect matching avoiding  $e$ . Since  $G$  is matching covered,  $e$  and  $f$  are vertex-disjoint. Let  $u$  and  $u'$  be the end-vertices of  $f$  and let  $G'$  be the graph  $G \setminus \{u, u'\} - e$ . By Tutte's theorem, there exists a subset  $S' \subseteq V(G')$  such that the number of odd components of the graph  $G' \setminus S'$  is at least  $|S'| + 1$ . Since the number of vertices of  $G'$  is even, the number of odd components of  $G' \setminus S$  is at least  $|S'| + 2$ .

Let  $S$  be the set  $S' \cup \{u, u'\}$ . The number of edges between  $S$  and  $\bar{S}$  is at most  $3|S| - 2$  since the vertices  $u$  and  $u'$  are joined by an edge. On the other hand, the number of edges leaving  $\bar{S}$  must be at least  $3|S| - 2$  since the graph  $G$  is 3-edge-connected and the equality can hold only if the edge  $e$  joins two different odd components of  $(G - e) \setminus S$ , these two components have two additional edges leaving them and all other components are odd components with exactly three edges leaving them. Let  $C_1$  and  $C_2$  be the two components incident with  $e$  and let  $C_3, \dots, C_{|S'|}$  be the other components. Since  $e$  is contained in no cyclic 3-edge-cut of  $G$ , the components  $C_1$  and  $C_2$  are single vertices.

Let  $H$  be the graph obtained from  $G - \{e, f\}$  by contracting the components  $C_3, \dots, C_{|S|}$  to single vertices, and let  $H_i$ ,  $i = 3, \dots, |S|$  be the graph obtained from  $C_i$  by introducing a new vertex incident with the three edges leaving  $C_i$ . Each  $H_i$ ,  $i = 3, \dots, |S|$  is matching-covered since it is a cubic bridgeless graph. Since perfect matchings of  $H_i$  combine with perfect matchings of  $H$ , it is enough to show that the bipartite graph  $H$  is matching-covered to establish that  $G - \{e, f\}$  is matching-covered.

Observe that  $H$  is 2-edge-connected: otherwise, the bridge of  $H$  together with  $e$  and  $f$  would form a cyclic 3-edge-cut of  $G$ .

Let  $v$  and  $v'$  be the end-vertices of the edge  $e$ . We construct an auxiliary graph  $H_0$  as follows: let  $U$  and  $V$  be the two color classes of  $H$ ,  $U$  containing  $u$  and  $u'$  and  $V$  containing  $v$  and  $v'$ . Replace each edge of  $H$  with a pair of edges, one directed from  $U$  to  $V$  whose capacity is two and one directed from  $V$  to  $U$  whose capacity is one. In addition, introduce new vertices  $u_0$  and  $v_0$ . Join  $u_0$  to  $u$  and  $u'$  with directed edges of capacity two and join  $v$  and  $v'$  to  $v_0$  with directed edges of capacity two.

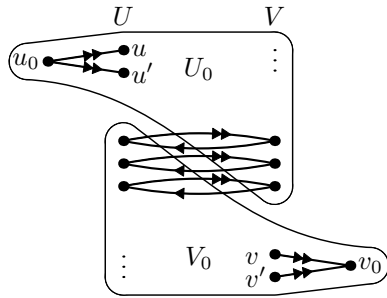

Figure 2: A graph with no flow from  $u_0$  to  $v_0$  of order four.

We claim that there exists a flow from  $u_0$  to  $v_0$  of order four. If there is no such flow, the vertices of  $H_0$  can be partitioned into two parts  $U_0$  and  $V_0$ ,  $u_0 \in U_0$  and  $v_0 \in V_0$ , such that the sum of the capacities of the edges from  $U_0$  to  $V_0$  is at most three. The fact that  $H$  is 2-edge-connected implies that  $\{u, u'\} \subseteq U_0$  and  $\{v, v'\} \subseteq V_0$ . Hence, the number of edges between  $U_0$  and  $V_0$  must be at least three since the edges between  $U_0$  and  $V_0$  correspond to an edge-cut in  $G$ . Since the sum of the capacities of these edges is at most three, all the three edges from  $U_0$  to  $V_0$  are directed from  $V$  to  $U$ , see Figure 2 for illustration. However, the number of edges between  $U \cap U_0$

and  $V \cap U_0$  in  $H$  is equal to 1 modulo three based on counting incidences with the vertices of  $U \cap U_0$  and equal to 0 modulo three based on counting incident with vertices of  $V \cap U_0$ , which is impossible. This finishes the proof of the existence of the flow.

Fix a flow from  $u_0$  to  $v_0$  of order four. Let  $ww'$  be an edge of  $H$  with  $w \in U$  and  $w' \in V$ . Assign the edge  $ww'$  weight of  $1/3$ , increase this weight by  $1/6$  for each unit of flow flowing from  $w$  to  $w'$  and decrease by  $1/6$  for each unit of flow from  $w'$  to  $w$ . Clearly, the final weight of  $ww'$  is  $1/6$ ,  $1/3$ ,  $1/2$  or  $2/3$ . It is easy to verify that the sum of edges incident with each vertex of  $H$  is equal to one. In particular, the vector with entries equal to the weights of the edges belongs to the perfect matching polytope. Since all its entries are non-zero, the graph  $H$  is matching-covered.

Let  $n_i$  be the number of vertices of  $C_i$ ,  $i = 3, \dots, |S|$ . Since  $H$  is bipartite, its brick and brace decomposition contains no bricks by Lemma 14. The number of bricks in the brick and brace decomposition of  $C_i$  is at most  $n_i/4$  by Lemma 13. Since  $n_3 + \dots + n_{|S|}$  does not exceed  $n - 4$ , the number of bricks in the brick and brace decomposition of  $G - \{e, f\}$  is at most  $n/4 - 1$ .  $\square$

**Lemma 18.** *Let  $G$  be an  $n$ -vertex 3-edge-connected cubic graph  $G$  and  $e$  an edge of  $G$  that is not contained in any cyclic 3-edge-cut of  $G$ . The number of perfect matchings of  $G$  that avoids  $e$  is at least  $n/8$ .*

*Proof.* If  $G - e$  is matching-covered, then  $b(G - e) \leq 3n/8 - 2$  by Lemma 15. By Theorem 11, the number of perfect matchings of  $G - e$  is at least

$$3n/2 - 1 - n + 1 - (3n/8 - 2) = n/8 + 2 \geq n/8 .$$

If  $G - e$  is not matching-covered, then there exists an edge  $f$  such that  $G - \{e, f\}$  is matching-covered and the number of bricks in the brick and brace decomposition of  $G - \{e, f\}$  is at most  $n/4 - 1$  by Lemma 17. Theorem 11 now yields that the number of perfect matchings of  $G - \{e, f\}$  is at least

$$3n/2 - 2 - n + 1 - (n/4 - 1) = n/4 \geq n/8 .$$

$\square$

## 4 Structure of the proof of Theorem 1

The proof is comprised by a series of lemmas – they are referenced by pairs X.a or triples X.a.b, where  $X \in \{A, B, C, D, E\}$  and  $a = 0, 1, \dots$  and

$b = 1, 2, \dots$ . In the proof of Lemma Y.c or Lemma Y.c.d, we use Lemmas X.a and Lemmas X.a.b with either  $a < c$  or  $a = c$  and X alphabetically preceding Y. The base of the whole proof is thus formed by Lemmas A.0, B.0, C.0.b, D.0.b and E.0.b,  $b \in \{1, 2, \dots\}$ .

**Lemma A.a** *There exists  $\beta \geq 0$  such that any 3-edge-connected  $n$ -vertex cubic graph  $G$  contains at least  $(a + 3)n/24 - \beta$  perfect matchings.*

**Lemma B.a** *There exists  $\beta \geq 0$  such that any  $n$ -vertex bridgeless cubic graph  $G$  contains at least  $(a + 3)n/24 - \beta$  perfect matchings.*

**Lemma C.a.b** *There exists  $\beta \geq 0$  such that for any cyclically 5-edge-connected cubic graph  $G$  and any edge  $e$  of  $G$ , the number of perfect matchings of an arbitrary  $b$ -expansion of  $G$  with  $n$  vertices that avoid the edge  $e$  is at least  $(a + 3)n/24 - \beta$ .*

**Lemma D.a.b** *There exists  $\beta \geq 0$  such that for any cyclically 4-edge-connected cubic graph  $G$  and any edge  $e$  of  $G$  that is not contained in any cyclic 4-edge-cut of  $G$ , the number of perfect matchings of an arbitrary  $b$ -expansion of  $G$  with  $n$  vertices that avoid the edge  $e$  is at least  $(a + 3)n/24 - \beta$ .*

**Lemma E.a.b** *There exists  $\beta \geq 0$  such that for any cyclically 4-edge-connected cubic graph  $G$  and any edge  $e$  of  $G$ , the number of perfect matchings of an arbitrary  $b$ -expansion of  $G$  with  $n$  vertices that avoid the edge  $e$  is at least  $(a + 3)n/24 - \beta$ .*

The series A, B, C, D, and E of the lemmas will be proved in Sections 5, 6, 7, 9, and 10, respectively. Section 8 will be devoted to the study of the connectivity of graphs obtained by cutting cyclically 4-edge-connected graphs into pieces.

## 5 Proof of A-series of lemmas

*Proof of Lemma A.a.* If  $a = 0$ , the claim follows from Theorem 8 with  $\beta = 0$ . Assume that  $a > 0$ . Let  $\beta_A$  be the constant from Lemma A.( $a - 1$ )

and  $\beta_E$  the constant from Lemma E.( $a-1$ ). $b$ , where  $b$  is the smallest integer such that

$$2^{b/655978752} \geq \frac{a+3}{24} b + 3.$$

Let  $\beta$  be the smallest integer larger than  $2\beta_A + 12$  and  $3\beta_E/2$  such that

$$2^{n/655978752} \geq \frac{a+3}{24} n - \beta$$

for every  $n$ .

We aim to prove with this choice of constants that any 3-edge-connected  $n$ -vertex cubic graph  $G$  contains at least  $(a+3)n/24 - \beta$  perfect matchings. Assume for the sake of contradiction that this is not the case, and take  $G$  to be a counterexample with the minimum order.

If  $G$  is cyclically 4-edge-connected, then every edge of  $G$  avoids at least  $(a+2)n/24 - \beta_E$  perfect matchings by Lemma E.( $a-1$ ). $b$ . Hence,  $G$  contains at least

$$\frac{3}{2} \cdot \frac{a+2}{24} n - \frac{3}{2} \beta_E \geq \frac{a+3}{24} n - \frac{3}{2} \beta_E$$

perfect matchings, as desired.

Let  $G$  contain a cyclic 3-edge-cut  $E(A, B)$ . Let  $e_i^A$  and  $e_i^B$  ( $i = 1, 2, 3$ ) be the edges corresponding to the three edges of the cut  $E(A, B)$  in  $G/A$  and  $G/B$ , respectively; let  $m_i^A$  ( $m_i^B$ ) be the number of perfect matchings of  $G/A$  ( $G/B$ ) containing  $e_i^A$  ( $e_i^B$ ),  $i = 1, 2, 3$ .

If both  $G/A$  and  $G/B$  are double covered, apply Lemma A.( $a-1$ ) to  $G/A$  and  $G/B$ . Let  $n_A = |A|$  and  $n_B = |B|$ . Then  $G/A$  and  $G/B$  have respectively at least

$$\frac{a+2}{24} (n_B + 1) - \beta_A \quad \text{and} \quad \frac{a+2}{24} (n_A + 1) - \beta_A$$

perfect matchings. Since  $G/A$  and  $G/B$  are double covered,  $m_i^A \geq 2$  and  $m_i^B \geq 2$  for  $i = 1, 2, 3$ . Hence, the number of perfect matchings of  $G$  is at least

$$\begin{aligned} \sum_{i=1}^3 m_i^A \cdot m_i^B &\geq \sum_{i=1}^3 (2 \cdot m_i^A + 2 \cdot m_i^B - 4) = 2 \cdot \sum_{i=1}^3 m_i^A + 2 \cdot \sum_{i=1}^3 m_i^B - 12 \geq \\ &\geq 2 \cdot \frac{a+2}{24} n - 2\beta_A - 12 \geq \frac{a+3}{24} n - 2\beta_A - 12. \end{aligned}$$

Otherwise, Lemma 9 implies that for every cyclic 3-edge-cut  $E(A, B)$  at least one of the graphs  $G/A$  and  $G/B$  is a Klee-graph. If both of them are Klee-graphs, then  $G$  is also a Klee-graph and the bound follows from Theorem 6 and the choice of  $\beta$ . Hence, exactly one of the graphs  $G/A$  and

$G/B$  is a Klee-graph. Assume that there exists a cyclic 3-edge-cut  $E(A, B)$  such that  $G/A$  is a Klee-graph with more than  $b$  vertices. Let  $n_A = |A|$  and  $n_B = |B|$ . By the minimality of  $G$ ,  $G/B$  has at least  $(a+3)(n_A+1)/24 - \beta$  perfect matchings. By the choice of  $b$ ,  $G/A$  has at least  $(a+3)(n_B+1)/24 + 3$  perfect matchings. Since  $G/A$  and  $G/B$  are matching covered,  $m_i^A \geq 1$  and  $m_i^B \geq 1$ ,  $i = 1, 2, 3$ . The perfect matchings of  $G/A$  and  $G/B$  combine to at least

$$\frac{a+3}{24}(n_B+1) + 3 + \frac{a+3}{24}(n_A+1) - \beta - 3 \geq \frac{a+3}{24}n - \beta$$

perfect matchings of  $G$ .

We can now assume that for every cyclic 3-edge-cut  $E(A, B)$  of  $G$ , one of  $G/A$  and  $G/B$  is a Klee-graph of order at most  $b$ . In this case, contract all the Klee sides of the cyclic 3-edge-cuts. The resulting cubic graph  $H$  is cyclically 4-edge-connected and  $G$  is a  $b$ -expansion of  $H$ . By Lemma E. $(a-1).b$ ,  $G$  has at least  $(a+2)n/24 - \beta_E$  perfect matchings avoiding any edge present in  $H$ . Hence,  $G$  contains at least

$$\frac{3}{2} \cdot \frac{a+2}{24}n - \frac{3}{2}\beta_E \geq \frac{a+3}{24}n - \beta$$

perfect matchings, as desired.  $\square$

## 6 Proof of B-series of lemmas

If  $G$  is a cubic bridgeless graph,  $E(A, B)$  a 2-edge-cut with  $A$  inclusion-wise minimal, then  $G[A]$  is called a *semiblock* of  $G$ . Observe that the semiblocks of  $G$  are always vertex disjoint. If  $G$  has no 2-edge-cuts, then it consists of a single semiblock formed by  $G$  itself. For a 2-edge-cut  $E(A, B)$  of  $G$ , let  $G_A$  ( $G_B$ ) be the graph obtained from  $G[A]$  ( $G[B]$ ) by adding an edge  $f_A$  ( $f_B$ ) between its two vertices of degree two. Observe that if  $G[A]$  is a semiblock, then  $s(G) = s(G_B) + 1$ , where the function  $s$  assigns the number of semiblocks.

**Lemma 19.** *If  $G$  is a cubic bridgeless graph, then any edge of  $G$  is avoided by at least  $s(G) + 1$  perfect matchings.*

*Proof.* The proof proceeds by induction on the number of semiblocks of  $G$ . If  $s(G) = 1$ , then the statement is folklore. Assume  $s(G) \geq 2$  and fix an edge  $e$  of  $G$ . Let  $E(A, B)$  be a 2-edge-cut of  $G$  such that  $G[A]$  is a semiblock. If  $e$  is contained in  $E(A, B)$  or in  $G[B]$ , then there are at least  $s(G_B) + 1 = s(G)$  perfect matchings avoiding  $e$  in  $G_B$  (if  $e$  is in  $E(A, B)$ , avoiding the edge

$f_B$ ). Choose among these perfect matchings one avoiding both  $e$  and  $f_B$ . This matching can be extended in two different ways to  $G[A]$  while the other matchings avoiding  $e$  extend in at least one way. Altogether, we have obtained  $s(G) + 1$  perfect matchings of  $G$  avoiding  $e$ .

Assume that  $e$  is inside  $G[A]$ .  $G_B$  contains at least  $s(G_B) + 1 = s(G)$  perfect matchings avoiding  $f_B$ . Each of them can be combined with a perfect matching of  $G_A$  avoiding  $e$  and  $f_A$  to obtain a perfect matching of  $G$  avoiding  $e$ . Moreover, a different perfect matching of  $G$  avoiding  $e$  can be obtained by combining a perfect matching of  $G_B$  containing  $f_B$  and a perfect matching of  $G_A$  avoiding  $e$  and containing  $f_A$  (if it exists). If such a perfect matching does not exist, there must be another perfect matching of  $G_A$  avoiding both  $e$  and  $f_A$ . Since  $s(G) \geq 2$  and  $G_A$  has at least two perfect matchings avoiding  $e$ , we obtain at least  $s(G) + 1$  perfect matchings of  $G$  avoiding  $e$ .  $\square$

*Proof of Lemma B.a.* Let  $\beta_A$  be the constant from Lemma A.a and set  $\beta = (\beta_A + 2)^2$ . First observe that Lemma A.a implies that if  $G$  is a cubic bridgeless graph with  $n$  vertices and  $s$  semiblocks, then  $G$  has at least  $(a + 3)n/24 - s(\beta_A + 2)$  perfect matchings. This can be proved by induction: if  $s = 1$  then  $G$  is 3-edge-connected and the result follows from Lemma A.a. Otherwise take a 2-edge-cut  $E(A, B)$  such that  $G[A]$  is a semiblock of  $G$ , with  $n_A = |A|$  and  $n_B = |B|$ . Fix a pair of canonical perfect matchings of  $G_A$ , one containing  $f_A$  and one avoiding it; fix another pair for  $G_B$ . Each perfect matching of  $G_A$  and each perfect matching of  $G_B$  can be combined with a canonical perfect matching of the other part to a perfect matching of  $G$ . Since two combinations of the canonical perfect matchings are counted twice, we obtain at least

$$\frac{a+3}{24} n_A - \beta_A + \frac{a+3}{24} n_B - (s-1)(\beta_A + 2) - 2 = \frac{a+3}{24} n - s(\beta_A + 2)$$

perfect matchings of  $G$ , which concludes the induction.

Consequently, if the number of semiblocks of  $G$  is smaller than  $\beta_A + 3$ , the assertion of Lemma B.a follows from Lemma A.a by the choice of  $\beta$ .

The rest of the proof proceeds by induction on the number of semiblocks of  $G$ , under the assumption that  $G$  has at least  $\beta_A + 3$  semiblocks. Let  $E(A, B)$  be a 2-edge-cut such that  $G[A]$  is a semiblock and let  $n_A = |A|$  and  $n_B = |B|$ . By the induction,  $G_B$  has at least  $(a + 3)n_B/24 - \beta$  perfect matchings, and by Lemma A.a,  $G_A$  has at least  $(a + 3)n_A/24 - \beta_A$  perfect matchings. Let  $m_f^A$  and  $m_{\emptyset}^A$  ( $m_f^B$  and  $m_{\emptyset}^B$ ) be the number of perfect matchings in  $G_A$  ( $G_B$ ) containing and avoiding the edge  $f_A$  ( $f_B$ ). Clearly,  $m_f^A$  and

$m_f^B$  are non-zero, and  $m_\emptyset^A \geq 2$ ; by Lemma 19,  $m_\emptyset^B \geq s(G_B) + 1 \geq \beta_A + 3$ . Then  $(m_\emptyset^A - 2) \cdot (m_\emptyset^B - \beta_A - 3) \geq 0$  and the number of perfect matchings of  $G$  is at least

$$\begin{aligned}
m_f^A \cdot m_f^B + m_\emptyset^A \cdot m_\emptyset^B &\geq m_f^A + m_f^B - 1 + (\beta_A + 3)m_\emptyset^A + 2m_\emptyset^B - 2(\beta_A + 3) \geq \\
&\geq m_f^A + m_\emptyset^A + m_f^B + m_\emptyset^B + (\beta_A + 2)m_\emptyset^A + m_\emptyset^B - 2\beta_A - 7 \\
&\geq \frac{a+3}{24} n_A - \beta_A + \frac{a+3}{24} n_B - \beta + 2(\beta_A + 2) + (\beta_A + 3) - 2\beta_A - 7 \\
&\geq \frac{a+3}{24} n - \beta.
\end{aligned}$$

□

## 7 Proof of C-series of lemmas

Given an edge  $e$  in a cyclically 5-edge-connected cubic graph  $G$ , there are several possible paths that can be split in such a way that perfect matchings of the reduced graph  $H$  avoiding an edge correspond to perfect matchings of  $G$  avoiding  $e$ . In the following two lemmas we prove that at least three of four such graphs  $H$  are 4-almost cyclically 4-edge-connected.

**Lemma 20.** *Let  $G$  be a cyclically 5-edge-connected cubic graph with at least 12 vertices and let  $v_1v_2v_3v_4$  be a path in  $G$ . Let  $v'_4$  be the neighbor of  $v_3$  different from  $v_2$  and  $v_4$ . At least one of the graphs  $H$  and  $H'$  obtained from  $G$  by splitting off the paths  $v_1v_2v_3v_4$  and  $v_1v_2v_3v'_4$ , respectively, is 4-almost cyclically 4-edge-connected.*

*Proof.* Let  $v'_1$  be the neighbor of  $v_2$  different from  $v_1$  and  $v_3$ . By Lemma 3, both  $H$  and  $H'$  are cyclically 3-edge-connected. Assume that neither  $H$  nor  $H'$  is cyclically 4-edge-connected. i.e.,  $H$  contains a cyclic 3-edge-cut  $E(A, B)$  and  $H'$  contains a cyclic 3-edge-cut  $E(A', B')$ . By Lemma 3, we can assume by symmetry that  $v_1 \in A \cap A'$ ,  $v'_1 \in B \cap B'$ ,  $v_4 \in A \cap B'$  and  $v'_4 \in A' \cap B$ , see Figure 3.

We first show that at least one of  $G[A]$ ,  $G[A']$ ,  $G[B]$  and  $G[B']$  is a triangle. Assume that this is not the case. Hence, each of  $A$ ,  $A'$ ,  $B$  and  $B'$  contains at least four vertices. Let  $d(X)$  be the number of edges leaving a vertex set  $X$  in  $G$ .

Assume first that  $|A \cap A'| = 1$ . Since  $|A| \geq 4$  and  $|A'| \geq 4$ , it follows that  $|A \cap B'| \geq 3$  and  $|A' \cap B| \geq 3$ . Since  $G$  is cyclically 5-edge-connected, then  $d(A \cap B') \geq 5$  and  $d(A' \cap B) \geq 5$ . As there is exactly one edge from  $A \cap B'$

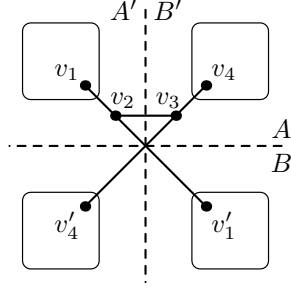

Figure 3: After splitting off the paths  $v_1v_2v_3v_4$  and  $v_1v_2v_3v'_4$  in  $G$  we obtain cyclic edge-cuts  $E(A, B)$  and  $E(A', B')$  in  $H$  and  $H'$ , respectively.

and one edge from  $A' \cap B$  leading to  $\{v_2, v_3\}$ ,  $|E(A, B)| + |E(A', B')| \geq d(A \cap B') + d(B \cap A') - 2 \geq 8$  which is a contradiction.

We conclude that  $|A \cap A'| \geq 2$  and, by symmetry,  $|A \cap B'| \geq 2$ ,  $|A' \cap B| \geq 2$  and  $|B \cap B'| \geq 2$ . Since  $G$  is cyclically 5-edge-connected, we have  $d(X \cap Y) \geq 4$  for each  $(X, Y) \in \{A, B\} \times \{A', B'\}$  (with equality if and only if  $X \cap Y$  consists of two adjacent vertices). As from each of the four sets  $X \cap Y$ , there is a single edge going to  $\{v_2, v_3\}$ , we obtain that the sum of  $d(X \cap Y)$ ,  $(X, Y) \in \{A, B\} \times \{A', B'\}$ , is at most  $2|E(A, B)| + 2|E(A', B')| + 4 = 16$ . Hence, all four sets  $X \cap Y$  consist of two adjacent vertices and there are no edges between  $A \cap A'$  and  $B \cap B'$ , and between  $A \cap B'$  and  $A' \cap B$ . In this case  $G$  must contain a cycle of length 3 or 4. Since  $G$  has at least 8 vertices, it would imply that  $G$  contains a cyclic edge-cut of size at most four, a contradiction.

We have shown that for any cyclic 3-edge-cuts  $E(A, B)$  in  $H$  and  $E(A', B')$  in  $H'$ , at least one of the graphs  $G[A]$ ,  $G[B]$ ,  $G[A']$  and  $G[B']$  is a triangle. This implies that in  $H$  or  $H'$ , say  $H$ , all cyclic 3-edge-cuts  $E(A, B)$  are such that  $G[A]$  or  $G[B]$  is a triangle. The only way a triangle can appear is that there is a common neighbor of one of the vertices  $v_1$  and  $v'_1$  and one of the vertices  $v_4$  and  $v'_4$ . Since  $G$  is cyclically 5-edge-connected, any pair of such vertices have at most one common neighbor (otherwise,  $G$  would contain a 4-cycle). In particular,  $H$  has at most two triangles and it is 4-almost cyclically 4-edge-connected.  $\square$

**Lemma 21.** *Let  $G$  be a cyclically 5-edge-connected cubic graph with at least 12 vertices and let  $v_1v_2v_3v_4$  and  $v_1v_2v'_3v'_4$  be paths in  $G$  with  $v_3 \neq v'_3$ . At*

least one of the graphs  $H$  and  $H'$  obtained from  $G$  by splitting off the paths  $v_1v_2v_3v_4$  and  $v_1v_2v'_3v'_4$ , respectively, is 4-almost cyclically 4-edge-connected.

*Proof.* Let  $v_5$  be the neighbor of  $v_3$  different from  $v_2$  and  $v_4$ , and let  $v'_5$  be the neighbor of  $v'_3$  different from  $v_2$  and  $v'_4$ . Again, by Lemma 3, both  $H$  and  $H'$  are cyclically 3-edge-connected. We assume that neither  $H$  nor  $H'$  is cyclically 4-edge-connected and consider cyclic 3-edge-cuts  $E(A, B)$  of  $H$  and  $E(A', B')$  of  $H'$ . For the sake of contradiction, assume that each of  $A, B, A'$ , and  $B'$  has the size at least four. By Lemma 3, we can also assume that  $\{v_1, v_4\} \subseteq A$  and  $\{v'_3, v_5\} \subseteq B$ . We claim that both  $v'_4$  and  $v'_5$  also belong to  $B$ . Clearly, at least one of them does (otherwise,  $G$  would contain a cyclic 2-edge-cut, which is impossible by Lemma 3). Say,  $v'_5$  does and  $v'_4$  does not. Let  $C = A \cup \{v_2, v_3, v'_3\}$  and  $D = B \setminus \{v'_3\}$ . The set  $D$  contains the vertices  $v_5$  and  $v'_5$ , which are distinct since  $G$  has no 4-cycle. The edge-cut  $E(C, D)$  is a 4-edge-cut in  $G$ , and since  $G$  is cyclically 5-edge-connected, we have  $D = \{v_5, v'_5\}$  and thus  $G[B]$  is a triangle as desired. A symmetric argument applies if  $v'_4$  is contained in  $B$  and  $v'_5$  is not. We conclude that we can restrict our attention without loss of generality to the following case:  $\{v_1, v_4\} \subseteq A$ ,  $\{v'_3, v_5, v'_4, v'_5\} \subseteq B$ ,  $\{v_1, v'_4\} \subseteq A'$  and  $\{v_3, v'_5, v_4, v_5\} \subseteq B'$ , see Figure 4.

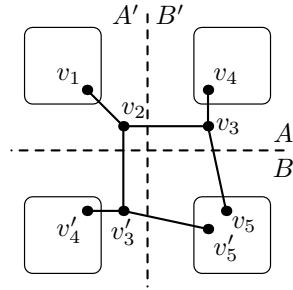

Figure 4: After splitting off the paths  $v_1v_2v_3v_4$  and  $v_1v_2v'_3v'_4$  in  $G$  we obtain cyclic edge-cuts  $E(A, B)$  and  $E(A', B')$  in  $H$  and  $H'$ , respectively.

As a consequence,  $|X \cap Y| \geq 1$  for each  $(X, Y) \in \{A, B\} \times \{A', B'\}$  and the set  $B \cap B'$  contains at least two vertices ( $v_5$  and  $v'_5$ ). If  $|A \cap A'| = 1$ , then both  $|A \cap B'|$  and  $|B \cap A'|$  are at least three. Consequently,  $d(A \cap B') \geq 5$  and  $d(A' \cap B) \geq 5$  where  $d(X)$  is the number of edges leaving  $X$  in  $G$ . Since  $|E(A, B)| + |E(A', B')| \geq d(A \cap B') + d(A' \cap B) - 2 \geq 8$ , this case cannot

happen. Similarly, we obtain a contradiction if  $|A \cap B'| = 1$  by inferring that  $|E(A, B)| + |E(A', B')| \geq d(A \cap A') + d(B \cap B') - 3 \geq 7$ . Hence, each of the numbers  $d(X \cap Y)$ ,  $(X, Y) \in \{A, B\} \times \{A', B'\}$ , is at least four (with equality if and only if  $X \cap Y$  consists of two adjacent vertices) and their sum is at least 16. Since exactly five edges leave the sets  $X \cap Y$  to  $\{v_2, v_3, v'_3\}$ , we obtain that the sum of  $d(X \cap Y)$ ,  $(X, Y) \in \{A, B\} \times \{A', B'\}$ , is at most  $2|E(A, B)| + 2|E(A', B')| + 5 = 17$ . As a consequence, three of the sets  $X \cap Y$  consists of two adjacent vertices and there are no edges between  $A \cap A'$  and  $B \cap B'$ , and between  $A \cap B'$  and  $A' \cap B$ . In this case  $G$  must contain a cycle of length 3 or 4. Since  $G$  has at least 8 vertices, it would imply that it contains a cyclic edge-cut of size at most four, a contradiction.

We proved that for any cyclic 3-edge-cuts  $E(A, B)$  in  $H$  and  $E(A', B')$  in  $H'$ , at least one of the graphs  $G[A]$ ,  $G[B]$ ,  $G[A']$  and  $G[B']$  is a triangle. The rest of the proof follows the lines of the proof of Lemma 20.  $\square$

We can now prove the lemmas in the C series.

*Proof of Lemma C.a.b.* Let  $G$  be a cyclically 5-edge-connected graph,  $e = v_1v_2$  be an edge of  $G$ , and  $H$  be a  $b$ -expansion of  $G$  with  $n$  vertices. Our aim is to prove that for some  $\beta$  depending only on  $a$  and  $b$ ,  $H$  has at least  $(a + 3)n/24 - \beta$  perfect matchings avoiding  $e$ . If  $a = 0$ , consider the graph  $H'$  obtained from  $H$  by contracting the Klee-graphs corresponding to  $v_1$  and  $v_2$  into two single vertices. This graph is 3-edge-connected and  $e$  is not contained in a cyclic 3-edge-cut. Moreover,  $H'$  has at least  $n - 2b + 2$  vertices, so by Lemma 18,  $H'$  has at least  $n/8 - (b - 1)/4$  perfect matchings avoiding  $e$ , and all of them extend to perfect matchings of  $H$  avoiding  $e$ . The result follows if  $\beta \geq (b - 1)/4$ .

Assume that  $a \geq 1$ , and let  $\beta_E$  be the constant from Lemma E.( $a - 1$ ). $b$ . Further, let  $v_3$  and  $v'_3$  be the neighbors of  $v_2$  different from  $v_1$ , let  $v_4$  and  $v_5$  be the neighbors of  $v_3$  different  $v_2$ , and let  $v'_4$  and  $v'_5$  be the neighbors of  $v'_3$  different  $v_2$ . Consider the graphs  $G_1$ ,  $G_2$ ,  $G_3$  and  $G_4$  obtained from  $G$  by splitting off the paths  $v_1v_2v_3v_4$ ,  $v_1v_2v_3v_5$ ,  $v_1v_2v'_3v'_4$  and  $v_1v_2v'_3v'_5$  and after possible drop of at most four vertices (replacing two triangles with vertices) to obtain a cyclically 4-edge-connected graph. Let  $e$  also denote the new edges  $v_1v_4$  in  $G_1$ ,  $v_1v_5$  in  $G_2$ ,  $v_1v'_4$  in  $G_3$  and  $v_1v'_5$  in  $G_4$ . By Lemmas 20 and 21, at least three of the graphs  $G_i$ , say  $G_1$ ,  $G_2$ , and  $G_3$ , are cyclically 4-edge-connected, and by Lemma 3 the graph  $G_4$  is 3-edge-connected and  $e$  is not contained in a cyclic 3-edge-cut of  $G_4$ .

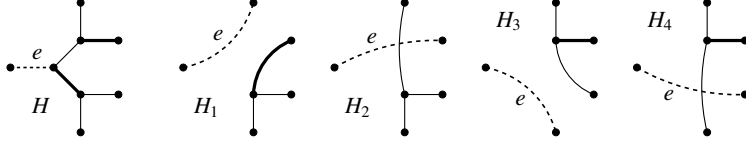

Figure 5: A perfect matching of  $H$  avoiding  $e$  and the corresponding perfect matchings of  $H_1$ ,  $H_3$  and  $H_4$  avoiding  $e$ .

For every  $1 \leq i \leq 4$ , let  $H_i$  be the  $b$ -expansion of  $G_i$  corresponding to  $H$  (expand the vertices present both in  $G$  and  $G_i$ , i.e., all the vertices but at most 8 vertices removed for  $G_i$ ,  $i = 1, 2, 3$  and 2 vertices removed from  $G_4$ ). In particular,  $H_1$ ,  $H_2$  and  $H_3$  have at least  $n - 8b$  vertices and  $H_4$  has at least  $n - 2b$  vertices. By Lemma E.( $a - 1$ ). $b$ , each of the graphs  $H_1$ ,  $H_2$  and  $H_3$  contains at least

$$\frac{a+2}{24}(n - 8b) - \beta_E$$

perfect matchings avoiding  $e$  and the graph  $H_4$  contains at least  $(n - 2b)/8$  such perfect matchings by Lemma 18. Observe that every perfect matching of  $H$  avoiding  $e$  corresponds to a perfect matching in at most three of the graphs  $H_1$ ,  $H_2$ ,  $H_3$ , and  $H_4$  (see Figure 5 for an example, where the perfect matchings are represented by thick edges). We obtain that  $H$  contains at least

$$\frac{1}{3} \cdot \left( 3 \cdot \left( \frac{a+2}{24}(n - 8b) - \beta_E \right) + \frac{n-2b}{8} \right) = \frac{a+3}{24}n - \beta_E - \frac{b}{12}(4a + 9)$$

perfect matchings avoiding  $e$ . The assertion of the lemma now follows by taking  $\beta = \max\{\beta_E + b(4a + 9)/12, (b - 1)/4\}$ .  $\square$

## 8 Cutting cyclically 4-edge-connected graphs

Consider a 4-edge-cut  $E(A, B) = \{e_1, \dots, e_4\}$  of a cubic graph  $G$ , and let  $v_i$  be the end-vertex of  $e_i$  in  $A$ . Let  $\{i, j, k, \ell\}$  be a permutation of  $\{1, 2, 3, 4\}$ . The graph  $G_{ij}^A$  is the cubic graph obtained from  $G[A]$  by adding two edges  $e_{ij}$  and  $e_{k\ell}$  between  $v_i$  and  $v_j$  and between  $v_k$  and  $v_\ell$ . The graph  $G_{(ij)}^A$  is the cubic graph obtained from  $G[A]$  by adding one vertex  $v_{ij}$  adjacent to  $v_i$  and  $v_j$ , one vertex  $v_{k\ell}$  adjacent to  $v_k$  and  $v_\ell$ , and by joining  $v_{ij}$  and  $v_{k\ell}$

by an edge denoted by  $e_{(ij)}^A$ . The edge between  $v_i$  and  $v_{ij}$  is denoted by  $e_i^A$ . We sometimes write  $G_{ij}$ ,  $G_{(ij)}$  and  $e_{(ij)}$  instead of  $G_{ij}^A$ ,  $G_{(ij)}^A$  and  $e_{(ij)}^A$  when the side of the cut is clear from the context. The constructions of these two types of graphs are depicted in Figure 6.

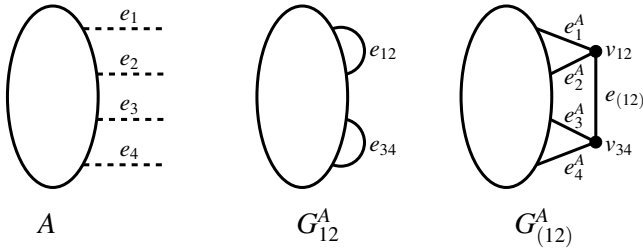

Figure 6: The graphs  $G_{12}^A$  and  $G_{(12)}^A$ .

**Lemma 22.** *Let  $G$  be a cyclically 4-edge-connected graph and  $E(A, B)$  a cyclic 4-edge-cut in  $G$ . All three graphs  $G_{(12)}^A$ ,  $G_{(13)}^A$  and  $G_{(14)}^A$  are 3-edge-connected with any of the edges  $e_i^A$  not being contained in a cyclic 3-edge-cut. If  $G[A]$  is not a cycle of length of four, then at least two of these graphs are cyclically 4-edge-connected.*

*Proof.* Recall that according to Observation 2, any 2-edge-cut in a cubic graph is cyclic. Hence, 3-edge-connected and cyclically 3-edge-connected is the same for cubic graphs.

First we prove that all three graphs  $G_{(12)}^A$ ,  $G_{(13)}^A$  and  $G_{(14)}^A$  are 3-edge-connected. Assume  $G_{(12)}^A$  has a (cyclic) 2-edge-cut  $E(C, D)$ . If both  $v_{12}$  and  $v_{34}$  are in  $D$ , then  $E(C, D' \cup B)$  is a 2-edge-cut in  $G$  (where  $D' = D \setminus \{v_{12}, v_{34}\}$ ), which is a contradiction with  $G$  being cyclically 4-edge-connected, see Figure 7, left. Therefore, by symmetry we can assume  $v_{12} \in C$  and  $v_{34} \in D$ . Let  $C' = C \setminus \{v_{12}\}$  and  $D' = D \setminus \{v_{34}\}$ , see Figure 7. Then  $E(C', D' \cup B)$  is a cyclic 3-edge-cut in  $G$  unless  $C'$  contains no cycle, which can happen only if it consists of a single vertex. Similarly we conclude that  $D'$  consists of a single vertex. But then  $A$  has no cycle, which is a contradiction.

Next, we prove that none of the edges of  $e_i^A$  is contained in a cyclic 3-edge cut in  $G_{(12)}^A$ ,  $G_{(13)}^A$  or  $G_{(14)}^A$ . For the sake of contradiction, assume  $G_{(12)}^A$  has

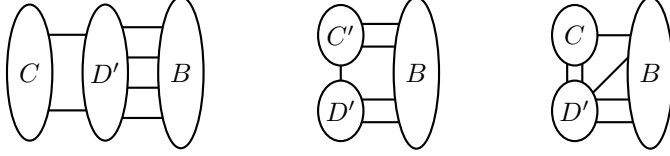

Figure 7: Smaller cyclic edge-cuts of  $G$  in the proof of Lemma 22.

a cyclic 3-edge-cut  $E(C, D)$  containing  $e_1$ . By symmetry, suppose  $v_1 \in C$  and  $v_{12} \in D$ . We claim that  $v_2$  and  $v_{34}$  belong to  $D$ : if not, moving  $v_{12}$  from  $D$  to  $C$  yields a 2-edge-cut in  $G_{(12)}^A$ . Let  $D' = D \setminus \{v_{12}, v_{34}\}$ , see Figure 7, right. Then  $E(C, D' \cup B)$  is a cyclic 3-edge-cut in  $G$ , a contradiction again.

Finally, assume that  $G_{(12)}^A$  and  $G_{(13)}^A$  are not cyclically 4-edge-connected. Let  $E(C, D)$  and  $E(C', D')$  be cyclic 3-edge-cuts in  $G_{(12)}^A$  and  $G_{(13)}^A$ , respectively. Just as above, it is easy to see that  $v_{12}$  and  $v_{34}$  ( $v_{13}$  and  $v_{24}$ ) do not belong to the same part of the cut  $(C, D)$  (the cut  $(C', D')$  respectively). Let  $v_{12} \in C$ ,  $v_{34} \in D$ ,  $v_{13} \in C'$ ,  $v_{24} \in D'$ . Using the same arguments as in the previous paragraph we conclude that  $v_1 \in C \cap C'$ ,  $v_2 \in C \cap D'$ ,  $v_3 \in D \cap C'$ ,  $v_4 \in D \cap D'$ .

For each  $(X, Y) \in \{C, D\} \times \{C', D'\}$  the number of edges leaving  $X \cap Y$  in  $G$  is at least 3 (with equality if and only if  $X \cap Y$  consists of a single vertex). As from each of the four sets  $X \cap Y$  there is a single edge going to  $B$ , the number of edges among the four sets within  $G[A]$  is at least  $\frac{1}{2}(4 \cdot 2) = 4$ . On the other hand, since  $E(C, D)$  and  $E(C', D')$  are 3-edge-cuts and the edges  $e_{(12)}$  and  $e_{(13)}$  are contained in the cuts, the number of edges among the four sets within  $G[A]$  is at most 4. Hence, all four sets  $X \cup Y$  consist of a single vertex  $v_i$  and there are no edges between  $C \cap C'$  and  $D \cap D'$ , and between  $C \cup D'$  and  $C' \cup D$ . Since there can be no parallel edges in  $G$ , for the other four pairs of  $X$  and  $Y$  there is precisely one edge between the corresponding vertices in  $X$  and  $Y$ . It is easy to see that in this case  $G[A]$  is a cycle of length four.  $\square$

**Lemma 23.** *Let  $G$  be a cyclically 4-edge-connected graph and  $E(A, B)$  a cyclic 4-edge-cut in  $G$ . If  $G[A]$  is neither a cycle of length of four nor the 6-vertex graph depicted in Figure 8, then at least one of the following holds:*

- all three graphs  $G_{(12)}^A$ ,  $G_{(13)}^A$  and  $G_{(14)}^A$  are cyclically 4-edge-connected,

- for some  $2 \leq i \neq j \leq 4$ , the graphs  $G_{(1i)}^A$ ,  $G_{(1j)}^A$  and  $G_{1i}^A$  are cyclically 4-edge-connected.

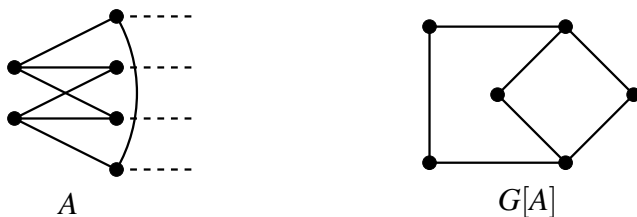

Figure 8: The exceptional graph of Lemma 23.

*Proof.* We assume that  $G[A]$  is not a cycle of length four. For the sake of contradiction, suppose that  $G_{(12)}^A$  and  $G_{(13)}^A$  are cyclically 4-edge-connected, but  $G_{12}^A$ ,  $G_{13}^A$ , and  $G_{(14)}^A$  are not. Let  $E(C_2, D_2)$ ,  $E(C_3, D_3)$ , and  $E(C_4, D_4)$  be cyclic 2- or 3-edge-cuts in  $G_{12}^A$ ,  $G_{13}^A$ , and  $G_{(14)}^A$ , respectively. Note that  $G_{12}^A$  and  $G_{13}^A$  can contain 2-edge-cuts.

Consider the vertices  $v_1, v_2, v_3$ , and  $v_4$ . If at least three of them are in  $D_2$ , then  $E(C_2, D_2 \cup B)$  is a cyclic 2- or 3-edge-cut in  $G$ . If  $v_1$  and  $v_3$  are in  $C_2$  and  $v_2$  and  $v_4$  in  $D_2$ , then  $E(C_2, D_2 \cup B)$  is a cyclic 2- or 3-edge-cut in  $G$  again. Therefore, by symmetry we can assume  $v_1, v_2 \in C_2$  and  $v_3, v_4 \in D_2$ . Analogously, we can assume  $v_1, v_3 \in C_3$  and  $v_2, v_4 \in D_3$ . Using the same arguments as in the proof of Lemma 22 we conclude that  $v_1, v_4, v_{14} \in C_4$  and  $v_2, v_3, v_{23} \in D_4$ . Hence, the sets  $X_1 = C_2 \cap C_3 \cap C_4$ ,  $X_2 = C_2 \cap D_3 \cap D_4$ ,  $X_3 = D_2 \cap C_3 \cap D_4$ , and  $X_4 = D_2 \cap D_3 \cap C_4$  are non-empty, since they contain  $v_1, v_2, v_3$ , and  $v_4$ , respectively.

Let  $X_5 = D_2 \cap D_3 \cap D_4$ ,  $X_6 = D_2 \cap C_3 \cap C_4$ ,  $X_7 = C_2 \cap D_3 \cap C_4$ ,  $X_8 = C_2 \cap C_3 \cap D_4$ . Let  $d(X)$  be the number of edges leaving a vertex set  $X$  in  $G$ . We have  $d(X_i) \geq 3$  for each  $i$  such that  $X_i$  is non-empty, in particular for  $i = 1, 2, 3, 4$  (with equality if and only if  $X_i$  consists of a single vertex). As from each of the four sets  $X_1, X_2, X_3, X_4$  there is a single edge going to  $B$ , the number of edges among the eight sets  $X_i$  ( $1 \leq i \leq 8$ ) within  $G[A]$  is at least  $\frac{1}{2}(4 \cdot 2 + k \cdot 3) = 4 + \frac{3}{2}k$ , where  $k$  is the number of non-empty sets  $X_i$  for  $i = 5, 6, 7, 8$ .

On the other hand, the number of edges among the eight sets is at most 8, since there are three 3-edge-cuts, and the edge  $e_{(14)}$  is in  $E(C_4, D_4)$ . Therefore,  $k \leq 2$ .

If  $k = 0$ , the number of edges among the four sets  $X_i$ ,  $i = 1, 2, 3, 4$ , is at least 4. On the other hand, each edge is counted in precisely two cuts, thus the number of edges is exactly 4 and the four sets are singletons. In this case  $G[A]$  is a cycle of length four, a contradiction.

Assume that  $k = 1$  and fix  $i \in \{1, 2, 3, 4\}$  such that  $X_{4+i}$  is non-empty. The number of edges among the five non-empty sets is at least  $6 > 4 + \frac{3}{2}$ . On the other hand, each edge from  $X_i$  (there are at least 2 such edges) is counted in at least two cuts, thus, the number of edges is at most  $8 - 2 = 6$ . Therefore, the number of edges is precisely 6 and four of the five sets are singletons. Moreover, precisely two edges are contained in two edge-cuts and four edges are contained in precisely one edge-cut. The four edges can only join  $X_{i+4}$  to some of the sets  $X_1, X_2, X_3, X_4$  except for  $X_i$ . Hence,  $X_{i+4}$  contains at least two vertices, thus,  $X_1, X_2, X_3, X_4$  are singletons. Since there are no edges between  $X_i$  and  $X_{i+4}$ , there are at least two edges between  $X_{i+4}$  and some  $X_j$ ,  $j \neq i$ . But then there are at most three edges leaving  $X_{i+4} \cup X_j$  (which contains at least three vertices) in  $G$ , a contradiction with  $G$  being cyclically 4-edge-connected.

Assume now that  $k = 2$  and let  $X_{i+4}$  and  $X_{j+4}$ ,  $1 \leq i < j \leq 4$  be non-empty. The number of edges among the six non-empty sets is at least  $7 = 4 + \frac{3}{2} \cdot 2$  and at most 8. If the number of edges is 8, each of them is contained in one edge-cut only. Then the edges leaving  $X_i$  (there are at least two of them) can only end in  $X_{j+4}$ , and the edges leaving  $X_j$  can only end in  $X_{i+4}$ . Since the edges between  $X_i$  and  $X_{j+4}$  and between  $X_j$  and  $X_{i+4}$  belong to the same cut, this cut contains at least four edges, a contradiction. Therefore, the number of edges is 7; all the six sets are singletons and precisely one edge belongs to two cuts. Since there can be at most one edge between any two sets, the edge contained in two cuts is the edge from  $v_i \in X_i$  to  $v_j \in X_j$ . The remaining six edges are the three edges from  $v_{i+4} \in X_{i+4}$  to all  $v_k$ ,  $k \in \{1, 2, 3, 4\} \setminus \{i\}$  and the three edges from  $v_{j+4} \in X_{j+4}$  to all  $v_k$ ,  $k \in \{1, 2, 3, 4\} \setminus \{j\}$ . The graph  $G[A]$  is thus isomorphic to the exceptional graph depicted in Figure 8.  $\square$

Cyclic 4-edge-cuts containing a given edge  $e$  in a cyclically 4-edge-connected graph turn out to be linearly ordered:

**Lemma 24.** *Let  $G$  be a cyclically 4-edge-connected graph, and  $e$  an edge contained in a cyclic 4-edge-cut of  $G$ . There exist  $A_1 \subseteq A_2 \subseteq \dots \subseteq A_k$*

and  $B_i = V(G) \setminus A_i$ ,  $i = 1, \dots, k$ , such that every cyclic 4-edge-cut of  $G$  containing  $e$  is of the form  $E(A_i, B_i)$ .

*Proof.* Consider two cyclic 4-edge-cuts  $E(A, B)$  and  $E(A', B')$ , such that the end-vertices of  $e$  lie in  $A \cap A'$  and  $B \cap B'$  respectively. Observe that  $A, B, A', B'$  all induce 2-edge-connected graphs. In order to establish the lemma, it is enough to show that  $A \cap B' = \emptyset$  or  $A' \cap B = \emptyset$ . If this is not the case, then for every  $X \in \{A \cap A', B \cap B'\}$  and  $Y \in \{A \cap B', B \cap A'\}$  there are at least two edges between  $X$  and  $Y$ . This implies that  $E(A, B)$  and  $E(A', B')$  both contain at least four edges distinct from  $e$ , a contradiction.  $\square$

## 9 Proof of D-series of lemmas

The idea to prove the D-series of the lemmas will be to split the graphs along cyclic 4-edge-cuts, play with the pieces to be sure that they are cubic with decent connectivity, apply induction on the pieces, and combine the perfect matchings in the different parts. However, we will see that combining perfect matchings will be quite difficult whenever a 2-edge-cut appears in one of the sides of a cyclic 4-edge-cut. Most of the results in this section (Lemmas 26 to 30) will allow us to overcome this difficulty.

**Lemma 25.** *If  $G$  is a cyclically 4-edge-connected cubic bipartite graph with at least 8 vertices, then every edge is contained in at least 3 perfect matchings of  $G$ .*

*Proof.* Let  $e = uv$  be an edge of  $G$ . Observe that the graph  $H = G \setminus \{u, v\}$  has minimum degree two, since otherwise  $G$  would contain a cyclic edge-cut of size two or three. Since  $G$  is cubic and bridgeless, it has a perfect matching containing  $e$ , and  $H$  has a perfect matching  $M$ . Our aim is to find two different (but not necessarily disjoint) alternating cycles in  $H$  with respect to  $M$ . This will prove that  $H$  has at least three perfect matchings, which will imply that  $G$  has at least three perfect matchings containing  $e$ .

Let  $f$  be any edge contained in  $M$ . Start marching from  $f$  in any direction, alternating the edges in  $M$  and the edges not in  $M$  until you hit the path you marched on. Since  $G$  is bipartite, this yields an alternating cycle. If the cycle does not contain  $f$ , start marching from  $f$  in the other direction and obtain a different alternating cycle. If the cycle contains  $f$ , consider an edge not contained in the alternating cycle (such an edge exists since  $H$  has at least six vertices) and start marching on it until you hit a vertex visited before; this yields another alternating cycle.  $\square$

Let  $G$  be a cyclically 4-edge-connected graph. If  $E(A, B)$  is a cyclic 4-edge-cut, we say that  $B$  is *solid* if  $G[B]$  does not have a 2-edge-cut with at least two vertices on each of its sides, in particular,  $G[B]$  must have at least eight vertices.

For a graph containing only vertices of degree two and three, the vertices of degree two are called *corners*. If a graph is comprised of a single edge, its two end-vertices are also called corners. We call *twisted net* a graph being either a 4-cycle, or the graph inductively obtained from a twisted net  $G$  and a twisted net (or a single edge)  $H$  by adding edges  $uv$  and  $u'v'$  to the disjoint union of  $G$  and  $H$ , where  $u, u'$  and  $v, v'$  are corners of  $G$  and  $H$ , respectively. If  $H$  is a single edge, this operation is called an *incrementation*; it is the same as adding a path of length three between two corners of  $G$ . If  $H$  is a twisted net, the operation is called a *multiplication*. Observe that every twisted net has exactly four corners, and that the special graph on six vertices depicted in Figure 8 is a twisted net. The following lemma will be useful in the proof of lemmas in Series D:

**Lemma 26.** *Let  $G$  be a cyclically 4-edge-connected graph with a distinguished edge  $e$  that is not contained in any cyclic 4-edge-cut. If for every cyclic 4-edge-cut  $E(A, B)$  with  $e \in G[A]$ ,  $B$  is not solid, then for each such cut  $G[B]$  is a twisted net.*

*Proof.* Proceed by induction on the number of vertices in  $G[B]$ . If the number of vertices of  $B$  is at most six, the claim clearly holds. If  $B$  has more than six vertices, it can be split into parts as  $B$  is not solid. If they both contain a cycle, the claim follows by induction. Otherwise, one of them contains a cycle and the other is just an edge; the claim again follows by induction.  $\square$

Our aim is now to prove that twisted nets have an exponential number of perfect matchings (Lemma 27), and an exponential number of matchings covering all the vertices except two corners (Lemma 30). In order to prove this second result we need to consider the special case of bipartite twisted nets, and prove stronger results about them (Lemma 28).

**Lemma 27.** *If  $G$  is a twisted net with  $n$  vertices, then  $G$  has at least  $2^{n/18+2/3}$  perfect matchings.*

*Proof.* We proceed by induction on  $n$ . First assume that  $G$  was obtained from a single 4-cycle by a sequence of  $k \leq 6$  incrementations. If  $k \leq 1$ , then  $n \leq 6$  and  $G$  has at least  $2 \geq 2^{n/18+2/3}$  perfect matchings. If  $2 \leq k \leq 6$

it can be checked that  $G$  has at least 3 perfect matchings. Since  $n \leq 16$ , we have  $3 \geq 2^{n/18+2/3}$  and the claim holds. Assume now that there exist two twisted nets  $H_1$  and  $H_2$  on  $n_1$  and  $n_2$  vertices respectively, so that  $G$  was obtained from at most six incrementations of the multiplication of  $H_1$  and  $H_2$ . In this case  $n_1 + n_2 \geq n - 12$  and by the induction,  $G$  has at least  $2^{n_1/18+2/3} \cdot 2^{n_2/18+2/3} \geq 2^{n/18+2/3}$  perfect matchings.

So we can now assume that  $G$  was obtained from a twisted net  $H_0$  by a sequence of seven incrementations, say  $H_1, \dots, H_7 = G$ . For a twisted net  $H_i$  with corners  $v_i^1, \dots, v_i^4$ , and for any  $X \subseteq \{1, \dots, 4\}$  define the quantities  $m_X^{H_i}$  as the number of perfect matchings of  $H_i \setminus \{v_i^j, j \in X\}$ . Assume that  $H_1$  is obtained (without loss of generality) by adding the path  $v_0^1 v_1^2 v_1^1 v_0^2$  to  $H_0$ , and set  $v_1^3 = v_0^3$  and  $v_1^4 = v_0^4$ . We observe that  $m_{\emptyset}^{H_1} = m_{\emptyset}^{H_0} + m_{12}^{H_0}$  and  $m_{12}^{H_1} = m_{\emptyset}^{H_0}$ . Moreover, for every pair  $\{i, j\} \subset \{1, 2, 3, 4\}$  distinct from  $\{1, 2\}$ , we have that  $m_{ij}^{H_1} \geq m_{ij}^{H_0}$ . Therefore,  $m_{\emptyset}^{H_7} \geq 2 m_{\emptyset}^{H_0}$ . As a consequence,  $G$  has at least  $2 \cdot 2^{(n-14)/18+2/3} \geq 2^{n/18+2/3}$  perfect matchings, which concludes the proof of Lemma 27.  $\square$

**Lemma 28.** *Let  $G$  be a bipartite twisted net with  $n$  vertices. Then  $G$  has a pair of corners in each color class, say  $u_1, u_2$  and  $v_1, v_2$ , and the graphs  $G \setminus \{u_1, u_2, v_1, v_2\}$  and  $G \setminus \{u_i, v_j\}$  have a perfect matching for any  $i, j \in \{1, 2\}$ . Moreover, for some  $i, j \in \{1, 2\}$ , the graph  $G \setminus \{u_i, v_j\}$  has at least  $2^{n/18-2/9}$  perfect matchings.*

*Proof.* The fact that each color class contains two corners of  $G$ , as well as the existence of perfect matchings of  $G \setminus \{u_1, u_2, v_1, v_2\}$ , and  $G \setminus \{u_i, v_j\}$  for any  $i, j \in \{1, 2\}$ , easily follow by induction on  $n$  (we consider that the empty graph contains a perfect matching): if  $G$  was obtained from a twisted net  $H$  by an incrementation, a matching avoiding all four corners of  $G$  is the same as a matching avoiding two corners of different colors in  $H$  (which is assumed to exist by the induction). A matching avoiding two corners of different colors in  $G$  is either a perfect matching of  $H$  or a matching avoiding two corners of different colors in  $H$ . So we can assume that  $G$  was obtained from  $H_1$  and  $H_2$  by a multiplication. In this case a matching avoiding all four corners of  $G$  can be obtained by combining matchings avoiding all four corners in  $H_1$  and  $H_2$ . Let  $u_1, v_1$  be the corners of  $G$  lying in  $H_1$  and  $u_2, v_2$  be the corners of  $G$  lying in  $H_2$ . First assume that  $u_1, v_1$  are in one color class of  $G$ , and  $u_2, v_2$  are in the other one. In this case, matchings of  $G$  avoiding two corners of different colors are obtained by combining matchings of  $H_1$  and  $H_2$  avoiding two corners of different colors. Otherwise, since  $G$  is bipartite,

it means without loss of generality that  $u_1, u_2$  are in one color class, and  $v_1, v_2$  are in the other color class. A perfect matching of  $G \setminus \{u_1, v_1\}$  is then obtained by combining a perfect matching of  $H_1 \setminus \{u_1, v_1\}$  and a perfect matching of  $H_2$ . Let  $w_1$  be the corner of  $H_1$  of the same color as  $v_1$ , and let  $w_2$  be the corner of  $H_2$  with the same color as  $u_2$ . A perfect matching of  $G \setminus \{u_1, v_2\}$  is obtained by combining a perfect matching of  $H_1 \setminus \{v_1, w_1\}$  and a perfect matching of  $H_2 \setminus \{v_2, w_2\}$ . All other matchings of  $G$  avoiding two corners of different colors are obtained in one of these two ways.

Consider now the graph  $H$  obtained from  $G$  by adding two adjacent vertices  $u, v$  and by joining  $u$  to  $v_1, v_2$  and  $v$  to  $u_1, u_2$ . This graph is cubic, bridgeless, and bipartite, so by Theorem 7 it has at least  $(4/3)^{(n+2)/2}$  perfect matchings avoiding the edge  $uv$ . As a consequence, two corners of  $G$  in different color classes, say  $u_1, v_1$  are such that  $G \setminus \{u_1, v_1\}$  has at least  $\frac{1}{4}(4/3)^{(n+2)/2} \geq 2^{n/6-5/3}$  perfect matchings (we use that  $2^{1/3} \leq 4/3$ ). If  $n = 4$ ,  $G$  has at least  $1 = 2^{4/18-2/9}$  matching avoiding two corners. If  $6 \leq n \leq 12$ , it can be checked that  $G$  has at least  $2 \geq 2^{n/18-2/9}$  matchings avoiding two corners. If  $n \geq 14$ ,  $2^{n/6-5/3} \geq 2^{n/18-1/9} \geq 2^{n/18-2/9}$ , which concludes the proof.  $\square$

**Lemma 29.** *Suppose  $G$  is a non-bipartite twisted net with  $n$  vertices and corners  $v_1, \dots, v_4$ . If for every  $1 \leq i < j \leq 4$ , we denote by  $m_{ij}^G$  the number of perfect matchings of  $G \setminus \{v_i, v_j\}$ , then  $\prod_{1 \leq i < j \leq 4} m_{ij}^G \geq 2^{n/18+4/9}$ . In particular, all values  $m_{ij}^G$  are at least one.*

*Proof.* We prove the statement by induction on  $n$ . There is only one non-bipartite twisted net of order at most six (it is the special graph of Figure 8). In this graph, one value  $m_{ij}^G$  is two and the others are one. Hence, the product of the  $m_{ij}^G$  is at least  $2 \geq 2^{6/18+4/9}$ . Assume now that  $G$  was obtained from  $H$  by adding a path  $v'_1 v_2 v_1 v'_2$  between  $v'_1$  and  $v'_2$ . By Lemma 27,  $G \setminus \{v_1, v_2\}$  has at least  $2^{(n-2)/18+2/3} \geq 2^{n/18+4/9}$  perfect matchings. So we only have to make sure that all the other values  $m_{ij}^G$  are at least one. If the graph  $H$  is not bipartite, then by the induction, for any pair  $\{x, y\}$  of corners of  $G$  distinct from  $\{v_1, v_2\}$ , the graph  $G \setminus \{x, y\}$  also has a perfect matching. If  $H$  is bipartite, then  $v'_1$  and  $v'_2$  must lie in the same color class. By Lemma 28,  $H$  has a matching covering all the vertices except the four corners, and matchings covering all the vertices except any two corners belonging to different color classes. All these matchings extend to perfect matchings of  $G \setminus \{x, y\}$  for any pair of corners  $\{x, y\}$  distinct from  $\{v_1, v_2\}$ .

So we can assume that  $G$  was obtained from two twisted nets  $H_1$  and  $H_2$

of order  $n_1, n_2$  by a multiplication. Let  $v_1, v_3$  be the two corners of  $G$  lying in  $H_1$ , and let  $v_2, v_4$  be the two corners of  $G$  lying in  $H_2$ . If none of  $H_1, H_2$  is bipartite, then by induction it is easy to check that  $m_{ij}^G \geq 1$  for all  $1 \leq i < j \leq 4$ . Moreover, since  $H_1 \setminus \{v_1, v_3\}$  has a perfect matching,  $G \setminus \{v_1, v_3\}$  has at least  $2^{n_2/18+2/3}$  perfect matchings by Lemma 27. Similarly,  $G \setminus \{v_2, v_4\}$  has at least  $2^{n_1/18+2/3}$  perfect matchings. As a consequence,

$$\prod_{1 \leq i < j \leq 4} m_{ij}^G \geq 2^{n_2/18+2/3} \cdot 2^{n_1/18+2/3} \geq 2^{n/18+4/3} \geq 2^{n/18+4/9}.$$

Assume now that one of  $H_1, H_2$ , say  $H_1$ , is bipartite, while the other is not bipartite. Denote by  $u_1, u_3$  the corners of  $H_1$  distinct from  $v_1, v_3$ , in such way that the graphs  $H_1 \setminus \{u_1, v_1\}$  and  $H_1 \setminus \{u_3, v_3\}$  both have a perfect matching (this is possible by Lemma 28). Also denote by  $u_2$  and  $u_4$  the corners of  $H_2$  adjacent to  $u_1$  and  $u_3$  in  $G$ , respectively. Observe that the perfect matchings of  $H_2 \setminus \{v_2, v_4\}$  combine with perfect matchings of  $H_1$  to give perfect matchings of  $G \setminus \{v_2, v_4\}$ , and that perfect matchings of  $H_2 \setminus \{u_2, u_4\}$  combine with perfect matchings of  $H_1 \setminus \{u_1, v_1, u_3, v_3\}$  (their existence is guaranteed by Lemma 28) to give perfect matchings of  $G \setminus \{v_1, v_3\}$ . Also observe that for any  $i \in \{1, 3\}$  and  $j \in \{2, 4\}$ , a perfect matching of  $G \setminus \{v_i, v_j\}$  can be obtained by combining perfect matchings of  $H_1 \setminus \{v_i, u_i\}$  and  $H_2 \setminus \{u_{i+1}, v_j\}$ . As a consequence,

$$\prod_{1 \leq i < j \leq 4} m_{ij}^G \geq 2^{n_1/18+2/3} \cdot \prod_{1 \leq i < j \leq 4} m_{ij}^{H_2} \geq 2^{n_1/18+2/3} \cdot 2^{n_2/18+4/9} \geq 2^{n/18+4/9}.$$

Assume now that  $H_1, H_2$  are both bipartite. Since  $G$  is not bipartite, without loss of generality it means that  $v_1, v_3$  have different colors in  $H_1$  whereas  $v_2, v_4$  have the same color in  $H_2$ . Using that  $H_2$  has a perfect matching and a matching covering all the vertices except the four corners, and that both  $H_1$  and  $H_2$  have matchings covering all the vertices except any two corners in different color classes gives that for any pair  $\{u, v\} \subset \{v_1, v_2, v_3, v_4\}$ ,  $G \setminus \{u, v\}$  has a perfect matching. Hence, all values  $m_{ij}^G$  are at least one. Again, we denote by  $u_1, u_3$  the corners of  $H_1$  distinct from  $v_1, v_3$ , and by  $u_2$  and  $u_4$  the corners of  $H_2$  adjacent to  $u_1$  and  $u_3$  in  $G$ , respectively. By Lemma 28, without loss of generality one of  $H_1 \setminus \{v_1, v_3\}$ ,  $H_1 \setminus \{u_1, u_3\}$ , and  $H_1 \setminus \{v_1, u_1\}$  has at least  $2^{n_1/18-2/9}$  perfect matchings. If  $H_1 \setminus \{v_1, v_3\}$  has at least  $2^{n_1/18-2/9}$  perfect matchings, then by combining them with perfect matchings of  $H_2$  we obtain at least  $2^{n_1/18-2/9} \cdot 2^{n_2/18+2/3} \geq 2^{n/18+4/9}$  perfect matchings of  $G \setminus \{v_1, v_3\}$ . Assume that

this is not the case, then we still obtain at least  $2^{n_2/18+2/3}$  such perfect matchings since  $v_1, v_3$  have different colors in  $H_1$ . If  $H_1 \setminus \{u_1, u_3\}$  has at least  $2^{n_1/18-2/9}$  perfect matchings, they combine with perfect matchings of  $H_2 \setminus \{u_2, v_2, u_4, v_4\}$  to give at least  $2^{n_1/18-2/9}$  perfect matchings of  $G \setminus \{v_2, v_4\}$ . If  $H_1 \setminus \{v_1, u_1\}$  has at least  $2^{n_1/18-2/9}$  perfect matchings, they combine with perfect matchings of  $H_2 \setminus \{u_2, v_2\}$  to give at least  $2^{n_1/18-2/9}$  perfect matchings of  $G \setminus \{v_1, v_2\}$ . In any case,

$$\prod_{1 \leq i < j \leq 4} m_{ij}^G \geq 2^{n_1/18-2/9} \cdot 2^{n_2/18+2/3} \geq 2^{n/18+4/9}.$$

□

Lemmas 28 and 29 have the following immediate consequence:

**Lemma 30.** *If  $G$  is a twisted net with  $n$  vertices, then there exist two corners  $u, v$  of  $G$  such that  $G \setminus \{u, v\}$  has at least  $2^{n/108-1/27}$  perfect matchings.*

We now use these results to prove the D series of the lemmas.

*Proof of Lemma D.a.b.* Let  $G$  be a cyclically 4-edge-connected graph,  $e$  an edge of  $G$  not contained in a cyclic 4-edge-cut, and  $H$  a  $b$ -expansion of  $G$  with  $n$  vertices. Our aim is to prove that for some  $\beta$  depending only on  $a$  and  $b$ ,  $H$  has at least  $(a+3)n/24 - \beta$  perfect matchings avoiding  $e$ . If  $a = 0$ , then the lemma follows from Lemma 18 with  $\beta = (b-1)/4$  (see the proof of the C series). Assume now that  $a \geq 1$ . Let  $\beta_B$  be the constant from Lemma B.a,  $\beta_C$  the constant from Lemma C.a.b and  $\beta_E$  the constant from Lemma E.( $a-1$ ). $b$ , and set  $\beta$  to be the maximum of the numbers  $2\beta_B + 22$ ,  $(a+3)b/6 + \beta_B$ ,  $\beta_C$ ,  $(a+3)b/2 + 3\beta_E + 30$ ,  $21(a+3)b \cdot \ln 42(a+3)^2b + 2 + \beta_E$ , and  $\frac{a+3}{24} \kappa(a, b)$  (with  $\kappa(a, b)$  depending only on  $a$  and  $b$ , to be defined later in the proof). The proof proceeds by induction on the number of vertices of  $G$ .

If  $G$  is cyclically 5-edge-connected, the claim follows from Lemma C.a.b. Assume that  $G$  has a cyclic 4-edge-cut  $E(A, B)$  such that  $e$  is contained in  $G[A]$  and at least one of the following holds:

- (1)  $G[A]$  is a cycle of length four,
- (2)  $G[A]$  is the six-vertex exceptional graph of Figure 8,
- (3)  $B$  is a twisted net of size at least  $k$ , where  $k$  is the smallest integer such that  $2^{k/108-1/27} \geq (a+3)n/24$ , or

(4)  $B$  is solid.

Let  $E(A^*, B^*)$  be the edge-cut of  $H$  so that  $H[A^*]$  and  $H[B^*]$  are the expansions of  $G[A]$  and  $G[B]$ ; let  $n_A$  and  $n_B$  be the numbers of vertices of  $H[A^*]$  and  $H[B^*]$ . Let  $e_1, e_2, e_3$  and  $e_4$  be the edges of  $E(A, B)$ , let  $v_1, v_2, v_3$  and  $v_4$  be their end-vertices in  $A$ , and let  $v_1^H, v_2^H, v_3^H$  and  $v_4^H$  be their endvertices in  $H[A^*]$ . For  $X \subseteq \{1, 2, 3, 4\}$ , let  $g_X^A$  ( $h_X^A$ ) denote the number of matchings of  $G[A]$  ( $H[A^*]$ ) avoiding  $e$  and covering all the vertices of  $G[A]$  ( $H[A^*]$ ) except  $v_i$  ( $v_i^H$ ),  $i \in X$ . Similarly,  $g_X^B$  ( $h_X^B$ ) is used. For each of these types of matchings in  $H[A^*]$  and  $H[B^*]$  fix two matchings to be canonical (if they exist, if not fix at least one if possible) and for  $X = \emptyset$ , fix three matchings to be canonical (if they exist, if not, fix as many as possible). Let  $H_{ij}^A$  and  $H_{(ij)}^A$  ( $H_{ij}^B$  and  $H_{(ij)}^B$ ) be the expansions of  $G_{ij}^A$  and  $G_{(ij)}^A$  ( $G_{ij}^B$  and  $G_{(ij)}^B$ ), respectively, for  $\{i, j\} \subset \{1, 2, 3, 4\}$ .

First assume that  $G[A]$  is a cycle of length four. Without loss of generality, the edge  $e$  joins the end-vertices of  $v_1$  and  $v_4$ . Let  $H'$  be the graph obtained from  $H$  by contracting the expansions of the vertices of  $A$  into 4 single vertices. This graph has at least  $n - 4b$  vertices, and each perfect matching of  $H_{12}^B$  can be combined with a matching of  $G[A]$  avoiding  $e$  to give a perfect matching of  $H'$  avoiding  $e$ . Hence,  $H$  has at least

$$\frac{a+3}{24} n_B - \beta_B \geq \frac{a+3}{24} n - \frac{a+3}{6} b - \beta_B$$

perfect matchings avoiding  $e$ .

The case that  $G[A]$  is the six-vertex exceptional graph of Figure 8 will be addressed later in the proof.

Consider now the third case. If  $g_{\emptyset}^A \neq 0$ , then by Lemma 27 the graph  $G[B]$  has at least  $2^{n_B^G/18+2/3} \geq 2^{n_B^G/108-1/27} \geq (a+3)n/24$  perfect matchings, where  $n_B^G$  is the number of vertices of  $G[B]$ ; all such perfect matchings extend to perfect matchings of  $H$ .

Assume  $g_{\emptyset}^A = 0$ . By Lemma 30,  $g_{ij}^B \geq 2^{n_B^G/108-1/27} \geq (a+3)n/24$  for some  $\{i, j\} \subset \{1, 2, 3, 4\}$ . By Lemma 22, we may assume that the graphs  $G_{(12)}^A$  and  $G_{(13)}^A$  are cyclically 4-edge-connected. Since there are no perfect matchings in  $G_{(12)}^A$  containing the edge  $e_{12}^A$  and avoiding  $e$ , by Lemma 10 the graph  $G[A] \setminus e$  is bipartite and  $e$  joins two vertices of the same color class. Then by Lemma 10,  $G_{(13)}^A$  has a perfect matching containing  $e_1^A$  and avoiding  $e_4^A$ . Such perfect matchings must contain  $e_2^A$  and avoid  $e$ , thus  $g_{12}^A \neq 0$ . Similarly, we obtain that all the quantities  $g_X^A$  with  $|X| = 2$  are non-zero. Therefore, we can extend the matchings of  $G[B]$  avoiding the

vertices  $v_i^B$  and  $v_j^B$  to perfect matchings of  $H$ .

We now analyse case (4). Assuming that  $A$  contains at least 6 vertices and  $B$  is solid, we will estimate the numbers of perfect matchings of  $H$  canonical in one part and non-canonical in the other. We start with matchings canonical in  $H[A^*]$  and non-canonical in  $H[B^*]$  and show that there are at least  $(a+3)n_B/24 - \beta/2$  such perfect matchings in  $H$ .

We first assume that  $G[A] \setminus e$  is not a bipartite graph such that  $e$  joins two vertices of the same color. By Lemma 23, we can assume that one of the following two cases apply: all the graphs  $G_{(12)}^A$ ,  $G_{(13)}^A$  and  $G_{(14)}^A$  are cyclically 4-edge-connected, or all the graphs  $G_{(12)}^A$ ,  $G_{(13)}^A$  and  $G_{12}^A$  are cyclically 4-edge-connected.

Let us first deal with the case that the graphs  $G_{(1i)}^A$  with  $i = 2, 3, 4$  are cyclically 4-edge-connected. Since neither of these graphs can be of the form described in Lemma 10, there exists a perfect matching of  $G_{(1i)}^A$  containing  $e_{(1i)}$  and avoiding  $e$  and so  $g_{\mathcal{D}}^A \geq 1$ . In addition, for any distinct  $i, j, k \in \{1, 2, 3, 4\}$ ,  $g_{ij}^A + g_{ik}^A \geq 1$ , since there exists a perfect matching of  $G_{(jk)}^A$  containing  $e_i^A$  and avoiding  $e$ . Hence, by symmetry, we can assume that all the quantities  $g_{13}^A$ ,  $g_{14}^A$ ,  $g_{23}^A$  and  $g_{24}^A$  are non-zero. Now, since  $H_{(12)}^B$  is a cubic bridgeless graph, by Lemma B.a it has at least  $(a+3)n_B/24 - \beta_B$  perfect matchings, which all extend to  $H[A^*]$ . At most 11 of these matchings are canonical in  $H[B^*]$  and thus the number of perfect matchings avoiding  $e$  canonical in  $H[A^*]$  and non-canonical in  $H[B^*]$  is at least  $(a+3)n_B/24 - \beta_B - 11$ .

We now consider the case when the graphs  $G_{(12)}^A$ ,  $G_{(13)}^A$  and  $G_{12}^A$  are cyclically 4-edge-connected. As in the previous case,  $g_{\mathcal{D}}^A$  is non-zero. If  $g_{14}^A$  or  $g_{23}^A$  is zero, then we conclude that all the quantities  $g_{12}^A$ ,  $g_{13}^A$ ,  $g_{24}^A$  and  $g_{34}^A$  are non-zero and proceed as in the previous case. Hence, we can assume that both  $g_{14}^A$  and  $g_{23}^A$  are non-zero. If  $g_{1234}^A$  is also non-zero, we consider the graph  $H_{14}^B$  and argue that each of its perfect matchings can be extended to  $H[A^*]$  and obtain the bound. Finally, if  $g_{1234}^A$  is zero, then by considering matchings in  $G_{12}^A$  containing  $e_{12}$  and matchings containing  $e_{34}$  we obtain that both  $g_{12}^A$  and  $g_{34}^A$  are non-zero. In this case, all the perfect matchings of the graph  $H_{(13)}^B$  extend to  $H[A^*]$  and the result follows.

We can now assume that the graph  $G[A] \setminus e$  is bipartite (with color classes  $U, V$ ) and  $e$  joins two vertices in the same color class, say  $U$ . By degree counting argument, we obtain that it can be assumed without loss

of generality that  $v_1 \in U$  and  $v_2, v_3, v_4 \in V$ , or  $v_1, v_2, v_3, v_4 \in U$ .

In the first case, we can assume by Lemma 22 that the graphs  $G_{(12)}^A$  and  $G_{(13)}^A$  are cyclically 4-edge-connected. By Lemma 9,  $G_{(12)}^A$  is double covered, so it has two perfect matchings containing the edge  $e_{(12)}$ . Since these two perfect matchings avoid the edge  $e_2^A$ , they also avoid  $e$  by Lemma 10 and so  $g_{\emptyset}^A \geq 2$ . By Lemma 10,  $G_{(12)}^A$  has a perfect matching containing  $e_1^A$  and avoiding  $e_i^A$  for  $i = 3, 4$ . Since such perfect matchings avoid  $e_2^A$ , they also avoid  $e$ . Hence, we obtain that  $g_{13}^A$  and  $g_{14}^A$  are non-zero. A similar argument for the graph  $G_{(13)}^A$  yields that also  $g_{12}^A$  is non-zero. Consider now perfect matchings avoiding the edge  $e_i^B$  in  $H_{(1i)}^B$ , for  $i = 2, 3, 4$ . By Lemma 22, two of the graphs  $G_{(1i)}^B$  are cyclically 4-edge-connected; by Lemma E.(a-1).b there are at least  $(a+2)n_B/24 - \beta_E$  perfect matchings avoiding  $e_i^B$  in  $H_{(1i)}^B$ . The third graph  $G_{(1i)}^B$  is cyclically 3-edge-connected and  $e_i^B$  is not contained in a cyclic 3-edge-cut. Its expansion  $H_{(1i)}^B$  is cyclically 3-edge-connected, too, and the only cyclic 3-edge-cut containing  $e_i^B$  is the cut separating the expansion of  $v_i^B$  from the rest of the graph. Let  $H'$  be the graph obtained from  $H_{(1i)}^B$  by contraction of the Klee-graph corresponding to  $v_i^B$  in  $H_{(1i)}^B$  to a single vertex. The graph  $H'$  has at least  $n_B - b$  vertices; it is cyclically 3-edge-connected and  $e_i^B$  is not contained in a cyclic 3-edge-cut. Hence, by Lemma 18, the number of perfect matchings of  $H_{(1i)}^B$  avoiding  $e_i^B$  is at least  $(n_B - b)/8$ . Altogether, we get

$$2h_{12}^B + 2h_{13}^B + 2h_{14}^B + 3h_{\emptyset}^B \geq 2 \cdot \frac{a+2}{24} n_B + \frac{1}{8} n_B - \frac{1}{8} b - 2\beta_E.$$

As a consequence, non-canonical matchings of  $H[B^*]$  can be combined with canonical matchings of  $H[A^*]$  avoiding  $e$  to give at least

$$h_{12}^B + h_{13}^B + h_{14}^B + 2h_{\emptyset}^B - 12 \geq \frac{a+3}{24} n_B - \frac{1}{16} b - \beta_E - 12$$

perfect matchings of  $H$  avoiding  $e$ .

We now assume that  $v_1, v_2, v_3, v_4 \in U$ . Again, it can be assumed that the graphs  $G_{(12)}^A$  and  $G_{(13)}^A$  are cyclically 4-edge-connected. An application of Lemma 10 similar to the one in the previous paragraph yields that all the quantities  $g_X^A$  with  $|X| = 2$  are non-zero. Since  $B$  is solid, all the graphs  $G_{(ij)}^B$  with  $\{i, j\} \subseteq \{1, 2, 3, 4\}$  are cyclically 4-edge-connected. Hence, each  $H_{(ij)}^B$  contains at least  $(a+2)n_B/24 - \beta_E$  perfect matchings avoiding the edge  $e_{(ij)}^B$ . As a consequence,

$$2h_{12}^B + 2h_{13}^B + 2h_{14}^B + 2h_{23}^B + 2h_{24}^B + 2h_{34}^B \geq 3 \cdot \frac{a+2}{24} n_B - 3\beta_E.$$

Subtracting 12 matchings canonical in  $H[B^*]$ , we obtain that the number of perfect matchings avoiding  $e$  that are canonical in  $H[A^*]$  and non-canonical in  $H[B^*]$  is at least

$$\frac{3}{2} \cdot \frac{a+2}{24} n_B - \frac{3}{2} \beta_E - 12 \geq \frac{a+3}{24} n_B - \frac{3}{2} \beta_E - 12.$$

This concludes the counting of perfect matchings of  $H$  avoiding  $e$  that are canonical in  $H[A^*]$  and non-canonical in  $H[B^*]$ .

Observe that the bound just above also holds if  $G[A]$  is the exceptional six-vertex graph of Figure 8. The edge  $e$  cannot be a part of the 4-cycle (otherwise the first case would apply), nor be adjacent to it (otherwise  $e$  is contained in a cyclic 4-edge-cut in  $G$ ). Hence,  $G[A] \setminus e$  is bipartite,  $v_1, v_2, v_3, v_4$  have the same color and in particular  $e$  connects two vertices of the same color. In this case, since  $n \leq n_B + 6b$ ,  $H$  has at least

$$\frac{a+3}{24} n - \frac{a+3}{4} b - \frac{3}{2} \beta_E - 12$$

perfect matchings avoiding  $e$ . So from now on we can assume that  $G[A]$  is neither a 4-cycle nor the exceptional six-vertex graph of Figure 8.

We will now count the perfect matchings of  $H$  that are non-canonical in  $H[A^*]$  and canonical in  $H[B^*]$ . Our aim is to show that there are at least  $(a+3)n_A/24 - \beta/2$  such matchings.

Consider the graphs  $G_{(12)}^A$ ,  $G_{(13)}^A$  and  $G_{(14)}^A$ . Two of these graphs are cyclically 4-edge-connected by Lemma 22; the remaining one is 3-edge-connected. We claim it has no cyclic 3-edge-cut containing  $e$ . Assume  $G_{(12)}^A$  has a cyclic 3-edge-cut  $E(C, D)$  containing  $e$ . It is clear that the new edge  $e_{(12)}^A$  belongs to the cut; let  $f$  be the third edge of the cut. Then  $\{e, f, e_1, e_2\}$  and  $\{e, f, e_3, e_4\}$  are 4-edge-cuts in  $G$  containing  $e$ . Since  $G$  has no cyclic 4-edge-cuts containing  $e$ , both  $C \cap A$  and  $D \cap A$  consist of a pair of adjacent vertices. Then  $G[A]$  is a cycle of length 4, which was excluded above.

Lemmas E.( $a-1$ ). $b$  and 18 now imply that

$$2h_{12}^A + 2h_{13}^A + 2h_{14}^A + 2h_{23}^A + 2h_{24}^A + 2h_{34}^A + 3h_{\emptyset}^A \geq 2 \cdot \frac{a+2}{24} n_A - 2\beta_E + \frac{1}{8} (n_A - 2b).$$

By the choice of  $B$  as solid, all the graphs  $G_{(12)}^B$ ,  $G_{(13)}^B$  and  $G_{(14)}^B$  are cyclically 4-edge-connected. In particular, if none of them is the exceptional graph described in Lemma 10, then all the quantities  $g_X^B$  with  $|X| = 2$  are

non-zero and  $g_{\emptyset}^B \geq 2$  (here we use that cyclically 4-edge-connected graphs are double covered). The bound now follows by dividing the previous inequality by two and subtracting the at most 18 canonical matchings.

Otherwise, exactly two of the three graphs are of the form described in Lemma 10, and  $G[B]$  is bipartite. By symmetry, we can assume that  $v_1$  and  $v_2$  lie in one color class and  $v_3$  and  $v_4$  in the other. Considering the graphs  $G_{(13)}^B$  and  $G_{(14)}^B$ , we observe that each of the quantities  $g_{13}^B$ ,  $g_{14}^B$ ,  $g_{23}^B$  and  $g_{24}^B$  is at least two as the graphs  $G_{(13)}^B$  and  $G_{(14)}^B$  are double covered by Lemma 9. In addition, Lemma 25 applied to the bipartite graph  $G_{(12)}^B$  yields that  $g_{\emptyset}^B$  is at least three. Finally, observe that the graph  $G_{12}^B$  satisfies the conditions of Lemma 10. Hence, any perfect matching of  $G_{12}^B$  containing  $e_{12}$  also contains  $e_{34}$ , which implies that  $g_{1234}^B$  is non-zero and the number of matchings non-canonical in  $H[A^*]$  and canonical in  $H[B^*]$  is at least

$$2h_{13}^A + 2h_{14}^A + 2h_{23}^A + 2h_{24}^A + 3h_{\emptyset}^A + h_{1234}^A - 27.$$

Replace now  $B$  with the cycle of length four  $v_1v_3v_2v_4$  and observe that the resulting graph is cyclically 4-edge-connected. By Lemma E.(a-1).b, its expansion has

$$h_{13}^A + h_{14}^A + h_{23}^A + h_{24}^A + 2h_{\emptyset}^A + h_{1234}^A \geq \frac{a+2}{24} (n_A + 4) - \beta_E$$

perfect matchings avoiding  $e$ . Observe also that the graph  $G_{(12)}^A$  is 3-edge-connected and no cyclic 3-edge-cut contains  $e$ . Its expansion (except for the end-vertices of  $e$ ) has at least  $(n_A - 2b)/8$  perfect matchings avoiding  $e$ , thus,

$$h_{13}^A + h_{14}^A + h_{23}^A + h_{24}^A + h_{\emptyset}^A \geq \frac{1}{8} (n_A - 2b).$$

Summing the two previous inequalities, we obtain that the number of perfect matchings avoiding  $e$  that are non-canonical in  $H[A^*]$  and canonical in  $H[B^*]$  is at least

$$\frac{a+2}{24} (n_A + 4) + \frac{1}{8} n_A - \frac{1}{4} b - \beta_E - 27 \geq \frac{a+3}{24} n_A - \frac{1}{2} \beta.$$

The bound on the number of matchings now follows from the estimates on the perfect matchings canonical in one of the graphs  $H[A^*]$  and  $H[B^*]$  and non-canonical in the other. This finishes the first part of the proof of Lemma D.a.b.

Based on the analysis above, we may now assume that  $|A| \geq 8$  and if  $E(A, B)$  is a cyclic 4-edge-cut of  $G$  and  $e$  is contained in  $A$ , then  $G[B]$  is

a twisted net of size less than  $k$ , where  $k$  is the smallest integer such that  $2^{k/108-1/27} \geq (a+3)n/24$  (see Lemma 26). In particular, consider such a cyclic 4-edge-cut  $E(A, B)$  with  $B$  inclusion-wise maximal. Assume that  $G[B]$  is a non-bipartite twisted net. Then by Lemma 29 we have  $g_X^B \geq 1$  for any  $X \subset \{1, 2, 3, 4\}$  with  $|X| = 2$ . Moreover, by Lemma 27,  $g_\emptyset^B \geq 2$ . Then there are at least

$$h_{12}^A + h_{13}^A + h_{14}^A + h_{23}^A + h_{24}^A + h_{34}^A + 2h_\emptyset^A$$

perfect matchings avoiding  $e$  in  $H$ . Consider the graphs  $G_{(12)}^A$ ,  $G_{(13)}^A$  and  $G_{(14)}^A$ . Two of these graphs are cyclically 4-edge-connected by Lemma 22; the remaining one is 3-edge-connected and it has no cyclic 3-edge-cut containing  $e$ . Since  $|B| < k$ , their expansions have at least  $n - kb$  vertices. Hence, Lemmas E.(a-1).b and 18 imply that

$$\begin{aligned} & h_{12}^A + h_{13}^A + h_{14}^A + h_{23}^A + h_{24}^A + h_{34}^A + 2h_\emptyset^A \geq \\ & \geq \frac{1}{2} \left( 2 \cdot \frac{a+2}{24} (n - kb) - 2\beta_E + \frac{1}{8} (n - kb - 2b) \right) \geq \\ & \geq \frac{a+3}{24} n + \frac{1}{48} n - \frac{b}{8} (a+3)(k+1). \end{aligned}$$

Assume that  $G[B]$  is a bipartite twisted net. Let  $e_1, \dots, e_4$  be the edges of the cut ordered in such a way that matchings including  $e_i$  and  $e_{i+1}$ ,  $i = 1, 2, 3, 4$ , indices modulo four, extend to  $G[B]$  by Lemma 28. Moreover,  $g_{1234}^B \geq 1$  and  $g_\emptyset^B \geq 2$ . Then there are at least

$$h_{12}^A + h_{14}^A + h_{23}^A + h_{34}^A + h_{1234}^A + 2h_\emptyset^A$$

perfect matchings avoiding  $e$  in  $H$ . Let  $m_{12}$ ,  $m_{14}$ , and  $m_{(13)}$  be the number of perfect matchings avoiding  $e$  in the graphs  $H_{12}^A$ ,  $H_{14}^A$ , and  $H_{(13)}^A$ , respectively. Then

$$h_{12}^A + h_{14}^A + h_{23}^A + h_{34}^A + h_{1234}^A + 2h_\emptyset^A \geq \frac{1}{2} (m_{12} + m_{14} + m_{(13)}).$$

In the rest of this section, we show that we can assume that at least one of the following two cases applies:

- (1)  $G_{(13)}^A$  and one of the graphs  $G_{12}^A$  and  $G_{14}^A$  (say  $G_{12}^A$ ) are  $(2k+3)$ -almost cyclically 4-edge-connected, and  $G_{14}^A$  is 3-edge-connected with no cyclic 3-edge-cut containing  $e$ , or
- (2)  $G_{(13)}^A$  and one of the graphs  $G_{12}^A$  and  $G_{14}^A$  (say  $G_{12}^A$ ) are  $(2k+3)$ -almost cyclically 4-edge-connected, and the vertex set of  $G_{14}^A$  can be

partitioned into three parts  $X$ ,  $Y$  and  $Z$  such that  $E(X, Y \cup Z)$  and  $E(X \cup Y, Z)$  are cyclic 3-edge-cuts containing  $e$ ,  $G_{14}^A[Y]$  is a twisted net with  $|Y| < k$ , and both the graphs  $G_{14}^A/(X \cup Y)$  and  $G_{14}^A/(Y \cup Z)$  are 3-edge-connected with no cyclic 3-edge-cut containing  $e$ .

Observe that the expansions of  $G_{12}^A$ ,  $G_{14}^A$  and  $G_{(13)}^A$  have at least  $n - kb$  vertices. In the first case, we apply Lemma E.( $a-1$ ). $b$  to the first two graphs and Lemma 18 to the remaining one, obtaining that  $\frac{1}{2}(m_{12} + m_{14} + m_{(13)})$  is at least

$$\begin{aligned} & \frac{1}{2} \cdot \left( 2 \cdot \frac{a+2}{24} (n - (2k+3)b - kb) - 2\beta_E - \frac{n-kb-2b}{8} \right) \geq \\ & \geq \frac{a+3}{24} n + \frac{1}{48} n - \frac{b}{8} (a+3)(k+1) - \beta_E. \end{aligned}$$

In the second case, we again apply Lemma E.( $a-1$ ). $b$  to the first two graphs. Let  $e_1$  and  $e_2$  ( $e_3$  and  $e_4$ ) be the edges joining  $Y$  to  $X$  ( $Z$ , respectively) in the third graph, say  $G_{14}^A$ . Let  $v_1, v_2, v_3, v_4$  be end-vertices of  $e_1, e_2, e_3, e_4$  in  $Y$ . According to Lemmas 28 and 29, without loss of generality we may assume that  $G_{14}^A[Y] \setminus \{v_1, v_3\}$  and  $G_{14}^A[Y] \setminus \{v_2, v_4\}$  both have perfect matchings. Let  $h_i^X$  be the number of perfect matchings containing  $e_i$ ,  $i = 1, 2$ , in the graph obtained by  $G_{14}^A/(Y \cup Z)$  by expanding as in  $H$  all the vertices except for the end-vertex of  $e$ . Observe that such graph does not contain a cyclic 3-edge-cut containing  $e$ . Let  $h_i^Z$ ,  $i = 3, 4$  be defined analogously. Let  $n_X$  and  $n_Z$  be the numbers of vertices in the (full) expansions of  $G_{14}^A/(Y \cup Z)$  and  $G_{14}^A/(X \cup Y)$ . Since  $|Y| \leq k$  and  $|B| \leq k$ , the number of perfect matchings of  $G_{14}^A$  avoiding  $e$  is at least

$$\begin{aligned} & h_1^X \cdot h_3^Z + h_2^X \cdot h_4^Z \geq h_1^X + h_2^X + h_3^Z + h_4^Z - 2 \geq \\ & \geq \frac{1}{8} (n_X - b) + \frac{1}{8} (n_Z - b) \geq \frac{1}{8} (n - 2kb - 2b) - 2. \end{aligned}$$

In this case,  $\frac{1}{2}(m_{12} + m_{14} + m_{(13)})$  is at least

$$\begin{aligned} & \frac{1}{2} \cdot \left( 2 \cdot \frac{a+2}{24} (n - (2k+3)b - kb) - 2\beta_E - \frac{n-2kb-2b}{8} - 2 \right) \geq \\ & \geq \frac{a+3}{24} n + \frac{1}{48} n - \frac{b}{8} (a+3)(k+1) - 2 - \beta_E. \end{aligned}$$

Observe that  $2^{(k-1)/108-1/27} < \frac{a+3}{24} n$ . Then using  $2^{168} > e^{108}$  and the

fact that  $e^x \geq 1 + x$  for all  $x \in \mathbb{R}$  we get

$$\begin{aligned}
\frac{1}{48} n &= \frac{1}{2(a+3)} \cdot \frac{a+3}{24} n \geq \\
&\geq \frac{1}{2(a+3)} \cdot 2^{(k-1)/108-1/27} = \frac{1}{2(a+3)} \cdot 2^{(k-5)/108} > \\
&> \frac{1}{2(a+3)} \cdot e^{(k-5)/168} = 21(a+3)b \cdot e^{(k-5)/168-\ln 42(a+3)^2b} \geq \\
&\geq 21(a+3)b \cdot \left(1 + \frac{k-5}{168} - \ln 42(a+3)^2b\right) > \\
&> \frac{b}{8} (a+3)(k+1) - 21(a+3)b \cdot \ln 42(a+3)^2b.
\end{aligned}$$

The claim follows by the choice of  $\beta$ .

We now prove that (1) or (2) holds. Assume that one of the graphs  $G_{(12)}^A$ ,  $G_{(13)}^A$ , and  $G_{(14)}^A$  is not 4-almost cyclically 4-edge-connected, or one of the graphs  $G_{12}^A$ ,  $G_{13}^A$  and  $G_{14}^A$  is not 3-edge-connected. Then, without loss of generality  $G[A]$  contains a 2-edge-cut  $E(C, D)$  so that  $e$ ,  $v_1$ , and  $v_2$  are in  $C$ , and  $v_3$  and  $v_4$  are in  $D$ . By maximality of  $B$ , the 4-edge-cut  $E(C, D \cup B)$  of  $G$  is not cyclic and  $C$  consists of a single edge  $e = v_1v_2$ . On the other hand  $E(D, C \cup B)$  is a cyclic 4-edge-cut of  $G$  (since otherwise  $A$  would be a 4-cycle), so  $G[D]$  is a twisted net of size less than  $k$ . As a consequence  $G$  has at most  $2k + 2 \leq 216 \log_2(\frac{a+3}{24} n) + 12$  vertices. Since it has at least  $n/b$  vertices, we obtain that  $n$  is upper-bounded by a constant  $\kappa(a, b)$  depending only on  $a$  and  $b$  (which we do not compute here, since the computation is very similar to the previous one). Taking  $\beta$  to be at least  $\frac{a+3}{24} \kappa(a, b)$  yields the desired bound on the number of perfect matchings of  $H$  avoiding  $e$ . Therefore, we can assume in the following that the graphs  $G_{(12)}^A$ ,  $G_{(13)}^A$ , and  $G_{(14)}^A$  are 4-almost cyclically 4-edge-connected, and the graphs  $G_{12}^A$ ,  $G_{13}^A$ , and  $G_{14}^A$  are 3-edge-connected.

We now show that at least one of the graphs  $G_{12}$  and  $G_{14}$  is  $(2k + 3)$ -almost cyclically 4-edge-connected. Assume that this is not the case. Since the cyclic 3-edge-cuts of  $G_{1i}$  correspond to cyclic 4-edge-cuts in  $G_{(1i)}$  containing  $e_{1i}$ , Lemma 24 implies that they are linearly ordered. Therefore,  $G_{12}$  contains a cyclic 3-edge-cut  $E(C, D)$  and  $G_{14}$  contains a cyclic 3-edge-cut  $E(C', D')$  such that all the sets  $C, D, C', D'$  have size at least  $k + 2 \geq 4$ . Without loss of generality, we can assume that  $v_1 \in C \cap C'$ ,  $v_2 \in C' \cap D$ ,  $v_3 \in D \cap D'$ , and  $v_4 \in C \cap D'$ .

Assume there is an edge between  $C \cap C'$  and  $D \cap D'$ . Beside this edge, there are at most four more edges among the four sets  $X \cap Y$ ,  $X \in \{C, C'\}$ ,  $Y \in \{D, D'\}$ . On the other hand, there are at least two edges leaving

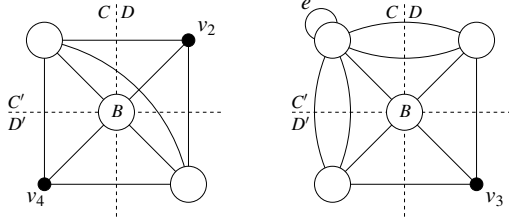

Figure 9: In the case where none of  $G_{12}$  and  $G_{14}$  is  $(2k+3)$ -almost cyclically 4-edge-connected.

$C \cap D'$  and at least two edges leaving  $D \cap C'$ . Hence, there are precisely two edges leaving both  $C \cap D'$  and  $D \cap C'$ ,  $C \cap D'$  and  $D \cap C'$  are  $\{v_4\}$  and  $\{v_2\}$  respectively, and  $C \cap C'$  and  $D \cap D'$  have size at least  $k+1 \geq 3$  (see Figure 9, left). Hence, the edge-cuts leaving  $C \cap C'$  and  $D \cap D'$  are cyclic 4-edge-cuts by Observation 2. Since  $e$  is not in a cyclic 4-edge-cut,  $e$  must lie in  $C \cap C'$  or  $D \cap D'$ . In both cases, this contradicts the maximality of  $B$ .

Consequently, we can assume without loss of generality that there are no edges between  $C \cap C'$  and  $D \cap D'$ , and between  $C \cap D'$  and  $D \cap C'$ . Hence, all six edges of the cuts are within  $C$ ,  $C'$ ,  $D$ , and  $D'$ . Without loss of generality, we may assume that there is at most one  $(C', D')$ -edge in  $D$  and at most one  $(C, D)$ -edge in  $D'$ . It means  $D \cap D'$  contains a single vertex  $\{v_3\}$ ,  $C \cap D'$  and  $D \cap C'$  have size at least  $k+1 \geq 3$  (see Figure 9, right). By maximality of  $B$ ,  $e$  is neither in  $C \cap D'$  nor in  $D \cap C'$ . The edges leaving  $C \cap D'$  form a cyclic 4-edge-cut, so by our assumption,  $G[C \cap D']$  is a twisted net of size at most  $k$ , a contradiction. This proves that one of  $G_{12}$  and  $G_{14}$ , say  $G_{14}$ , is  $(2k+3)$ -almost cyclically 4-edge-connected.

Assume now that  $G_{12}$  has a cyclic 3-edge-cut containing  $e$ . Observe that cyclic 3-edge-cuts of  $G_{12}$  containing  $e$  one-to-one correspond to such cyclic 4-edge-cuts of  $G_{(12)}$  and apply Lemma 24 to  $G_{(12)}$ . Set  $X = A_1$ ,  $Z = B_k$  and  $Y$  to be the remaining vertices. Clearly,  $Y$  must be a twisted net of size less than  $k$ . Observe that each of  $G/(X \cup Y)$  and  $G/(Y \cup Z)$  is cyclically 3-edge-connected. By minimality of  $X$  and  $Z$ ,  $e$  is not contained in a cyclic 3-edge-cut in any of these two graphs, as claimed.  $\square$

## 10 Proof of E-series of lemmas

This section is mainly devoted to counting perfect matchings avoiding an edge contained in a cyclic 4-edge-cut. A *ladder* of height  $k$  is a  $2 \times k$  grid. The two edges of a ladder having both end-vertices of degree two are called the *ends* of the ladder.

**Lemma 31.** *Let  $G$  be a cyclically 4-edge-connected graph and  $E(A, B)$  a cyclic 4-edge-cut of  $G$  containing the edges  $e_1, \dots, e_4$  having end-vertices  $v_1, \dots, v_4$  in  $A$ . For  $1 \leq i \neq j \leq 4$ , let  $g_{ij}^A$  be the number of matchings of  $G[A]$  covering all the vertices of  $A$  except for  $v_i, v_j$ . If one of the three numbers  $g_{23}^A, g_{24}^A$ , and  $g_{34}^A$  is zero, say  $g_{ij}^A$ , then either the other two are at least two, or one of them is one, say  $g_{ik}^A$ , and the subgraph  $G[A]$  is a ladder with ends  $v_1v_i$  and  $v_jv_k$ .*

*Proof.* Fix  $G$  and choose an inclusion-wise minimal set  $A$  in  $G$  that does not satisfy the statement of the lemma. By Lemma 22, we can assume that the graphs  $G_{(12)}^A$  and  $G_{(13)}^A$  are cyclically 4-edge-connected. By considering the matchings including the edges  $e_2$  and  $e_3$  in these two graphs, we obtain that  $g_{23}^A + g_{24}^A$  and  $g_{23}^A + g_{34}^A$  are at least two since every cyclically 4-edge-connected graph is double covered by Lemma 9. Hence, if  $g_{23}^A = 0$  then  $g_{24}^A \geq 2$  and  $g_{34}^A \geq 2$ . By symmetry we can now assume that  $g_{24}^A = 0$  and so  $g_{23}^A \geq 2$ . In order to prove the lemma, we only need to show that either  $g_{34}^A \geq 2$ , or  $g_{34}^A = 1$  and  $G[A]$  is a ladder with ends  $v_1v_4$  and  $v_2v_3$ .

By Lemma 10, there exists a proper 2-coloring of the vertices of  $G[A]$  such that  $v_1$  and  $v_3$  are in one color class, say  $C_1$ , while  $v_2$  and  $v_4$  are in the other class, say  $C_2$ . Consequently, the graph  $G_{(13)}$  is bipartite. By Lemma 10,  $G_{(13)}$  contains a matching avoiding  $e_1$  and containing  $e_4$ , i.e.,  $g_{34}^A \geq 1$ .

Assume that  $g_{34}^A = 1$ . By Lemma 4, the graph  $H$  obtained from  $G[A]$  by removing the vertices  $v_3$  and  $v_4$  has a bridge contained in the unique perfect matching of  $H$ . Define the *deficiency*  $d(H)$  of a subcubic graph  $H$  to be the sum of the differences between three and the degrees of the vertices. Since  $G_{(12)}^A$  is cyclically 4-edge-connected, the vertices  $v_3$  and  $v_4$  are not adjacent in  $G$ , hence,  $d(H)$  is six, three in each color class of  $H$ . Let  $V$  and  $W$  be such sets that the cut  $E(V, W)$  is formed by the bridge  $f$  of  $H$ . Since the bridge  $f$  is contained in the unique perfect matching of  $H$ , we can assume that  $|V \cap C_1| = |V \cap C_2| + 1$  and thus  $|W \cap C_1| = |W \cap C_2| - 1$ . It means that the subgraphs  $G[V]$  and  $G[W]$  induced by  $V$  and  $W$  have odd numbers of vertices, hence, their deficiencies (including the end-vertices of the bridge

$f$ ) are odd. On the other hand,  $d(G[V])$  and  $d(G[W])$  cannot be equal to one, otherwise  $f$  would be a bridge in  $G$ . Since  $d(G[V]) + d(G[W]) = 8$ , we can assume  $d(G[V]) = 3$  and  $d(G[W]) = 5$ . But then the three edges leaving  $V$  in  $G$  form a cyclic 3-edge-cut, unless  $G[V]$  is a single vertex  $w$ . Then  $V \cap C_1 = \{w\}$  and  $V \cap C_2 = \emptyset$ ; the degree of  $w$  in  $H$  is one.

The vertex  $w$  is thus either adjacent to  $v_3$  or  $v_4$ , or it is one of the vertices  $v_1$  and  $v_2$ . Since  $v_3$  and  $v_4$  are in different color classes,  $w$  is not adjacent to both of them. Since  $w \in C_1$ ,  $w = v_1$  and it is adjacent to  $v_4$ .

Let  $A' = A \setminus \{v_1, v_4\}$  and  $B' = B \cup \{v_1, v_4\}$ . We denote by  $v'_1$  and  $v'_4$  the neighbors of  $v_1$  and  $v_4$  in  $A'$ . If  $G[A]$  is not a cycle of length four, then  $E(A', B')$  is a cyclic 4-edge-cut. Observe that  $g_{24}^A = 0$  and  $g_{34}^A = 1$  implies  $g_{12}^A = 0$  and  $g_{13}^A = 1$ . So, by the minimality of  $A$ , the subgraph  $G[A']$  is a ladder with ends  $v'_1 v'_4$  and  $v_2 v_3$ . Hence,  $G[A]$  is a ladder with ends  $v_1 v_4$  and  $v_2 v_3$ .  $\square$

*Proof of Lemma E.a.b.* The proof proceeds by induction on the number of vertices in  $G$  (in addition, to the general induction framework).

Let  $G$  be a cyclically 4-edge-connected graph,  $e$  an edge of  $G$  and  $H$  a  $b$ -expansion of  $G$  with  $n$  vertices. Our aim is to prove that for some  $\beta$  depending only on  $a$  and  $b$ ,  $H$  has at least  $(a+3)n/24 - \beta$  perfect matchings avoiding  $e$ . If  $e$  is not contained in a cyclic 4-edge-cut of  $G$ , then this follows from Lemma D.a.b, so we can assume in the remaining of the proof that  $e$  is contained in a cyclic 4-edge-cut of  $G$ .

If  $a = 0$ , then the lemma follows from Lemma 18 with  $\beta = b/4$ . Assume that  $a > 0$  and let  $\beta_E$  be the constant from Lemma E.( $a-1$ ).b,  $\beta_D$  the constant from Lemma D.a.b and  $\beta_B$  the constant from Lemma B.a. Let  $\gamma$  be the least element of  $\{n \in \mathbb{N} \mid n \geq 4\}$  satisfying

$$2^{\gamma/4-2} \geq \frac{a+3}{24}(\gamma b) + 2$$

and  $\beta$  be the maximum of the following numbers:  $4\beta_E - 24$ ,  $(a+3)b/4$ ,  $(a+3)\gamma b/12 + \beta_D$ ,  $(a+3)\gamma b/12 + \beta_B$ ,  $(a+2)\gamma b/8 + 3\beta_E/2$ ,  $(a+2)(\gamma+1)b/6 + 2\beta_E$ .

Let  $A_1 \subseteq A_2 \cdots \subseteq A_k$  and  $B_k \subseteq B_{k-1} \cdots \subseteq B_1$  be as in the statement of Lemma 24. Assume first that there exists  $i_0$  such that neither  $G[A_{i_0}]$  nor  $G[B_{i_0}]$  is a ladder and they both contain at least eight vertices each. To simplify the presentation, we will write  $A$  instead of  $A_{i_0}$  and  $B$  instead of  $B_{i_0}$ . Let  $e_2, e_3, e_4$ , and  $e = e_1$  be the edges of the edge-cut  $E(A, B)$ . As previously,  $h_X^A$  denotes the number of matchings of the expansion  $H[A]$  of  $G[A]$  covering all the vertices except the end-vertices of  $e_i^A$ ,  $i \in X$ . The

quantities  $h_X^B$  are defined accordingly for  $G[B]$ . Finally, let  $E(A^*, B^*)$  be the edge-cut of  $H$  so that  $H[A^*]$  and  $H[B^*]$  are the expansions of  $G[A]$  and  $G[B]$ , and let  $n_A$  and  $n_B$  be the number of vertices of  $H[A^*]$  and  $H[B^*]$ .

By Lemma 23, without loss of generality at least one of the following holds:

- All the graphs  $G_{(12)}^A$ ,  $G_{(13)}^A$  and  $G_{(14)}^A$  are cyclically 4-edge-connected. By inspecting the types of perfect matchings avoiding  $e = e_1$  in these graphs, we obtain that the three quantities  $h_{23}^A + h_{24}^A + h_{\emptyset}^A$ ,  $h_{23}^A + h_{34}^A + h_{\emptyset}^A$ , and  $h_{24}^A + h_{34}^A + h_{\emptyset}^A$  are at least  $(a+2)(n_A+2)/24 - \beta_E$  by Lemma E.(a-1).b.
- All the graphs  $G_{(12)}^A$ ,  $G_{(13)}^A$  and  $G_{12}^A$  are cyclically 4-edge-connected. By inspecting the types of perfect matchings avoiding  $e$  in these graphs, we obtain that two quantities  $h_{23}^A + h_{24}^A + h_{\emptyset}^A$  and  $h_{23}^A + h_{34}^A + h_{\emptyset}^A$  are at least  $(a+2)(n_A+2)/24 - \beta_E$ , while

$$h_{34}^A + h_{\emptyset}^A \geq \frac{a+2}{24} n_A - \beta_E.$$

In any case, all the quantities  $h_{23}^A + h_{24}^A + h_{\emptyset}^A$ ,  $h_{23}^A + h_{34}^A + h_{\emptyset}^A$ , and  $h_{24}^A + h_{34}^A + h_{\emptyset}^A$  are at least  $(a+2)n_A/24 - \beta_E$ .

A symmetric argument now yields that all the quantities  $h_{23}^B + h_{24}^B + h_{\emptyset}^B$ ,  $h_{23}^B + h_{34}^B + h_{\emptyset}^B$ , and  $h_{24}^B + h_{34}^B + h_{\emptyset}^B$  are at least  $(a+2)n_B/24 - \beta_E$ .

Choose one or two (two if possible) canonical matchings for each of the four possible types avoiding  $e$  (23, 24, 34, and  $\emptyset$ ). Since one of the graphs  $G_{(ij)}^A$  is cyclically 4-edge-connected, it is double covered by Lemma 9 and so  $h_{\emptyset}^A \geq 2$ . Similarly, we have  $h_{\emptyset}^B \geq 2$ . If all  $h_{23}^A$ ,  $h_{24}^A$  and  $h_{34}^A$  are non-zero, then the number of combinations of a canonical matching in  $H[A^*]$  and a non-canonical matching in  $H[B^*]$  is at least

$$\begin{aligned} h_{23}^B + h_{24}^B + h_{34}^B + 2h_{\emptyset}^B - 10 &\geq h_{23}^B + h_{24}^B + h_{34}^B + \frac{3}{2} h_{\emptyset}^B - 10 \\ &\geq \frac{3}{2} \cdot \left( \frac{a+2}{24} n_B - \beta_E \right) - 10 \\ &\geq \frac{a+3}{24} n_B - \frac{3}{2} \beta_E - 10. \end{aligned}$$

If one of the quantities is zero, say  $h_{34}^A = 0$ , then  $g_{34}^A = 0$  and Lemma 31 yields  $g_{23}^A$  and  $g_{24}^A$  (as well as  $h_{23}^A$  and  $h_{24}^A$ ) are at least two since  $G[A]$  is not a ladder (recall that we assumed that for the 4-edge-cut  $E(A, B)$  containing  $e$ , neither  $G[A]$  nor  $G[B]$  is a ladder). Hence, the number of combinations of a canonical matching in  $H[A^*]$  and a non-canonical matching in  $H[B^*]$

is at least

$$\begin{aligned} 2h_{23}^B + 2h_{24}^B + 2h_{\emptyset}^B - 12 &\geq 2 \cdot \left(\frac{a+2}{24} n_B - \beta_E\right) - 12 \\ &\geq \frac{a+3}{24} n_B - 2\beta_E - 12. \end{aligned}$$

Similarly, we estimate combinations of non-canonical matchings in  $H[A^*]$  and canonical matchings of  $H[B^*]$  to be at least  $(a+3)n_A/24 - 2\beta_E - 12$ . Hence, the expansion of  $G$  has at least  $(a+3)n/24 - 4\beta_E - 24$  perfect matchings avoiding  $e$ .

In the rest, we assume that whenever  $G[A_i]$  and  $G[B_i]$  have at least 8 vertices, at least one of them is a ladder. Assume there is at least one cut such that both parts have at least 8 vertices. It is clear that if  $G[A_{i_0}]$  is a ladder, then for all  $i \leq i_0$   $G[A_i]$  is a ladder too. Analogously, if  $G[B_{j_0}]$  is a ladder, then for all  $j \geq j_0$   $G[B_j]$  is a ladder too. Let  $i_0$  be the largest  $i$  such that  $G[A_i]$  is a ladder. Then if  $i_0 < k$ ,  $G[A_{i_0+1}]$  is not a ladder, and therefore,  $G[B_{i_0+1}]$  is either a ladder or a graph on at most 6 vertices.

Assume that  $G[A_{i_0}]$  is a ladder with at least  $\gamma$  vertices (recall that  $\gamma$  was defined as the least integer satisfying  $2^{\gamma/4-2} \geq (a+3)\gamma b/24 + 2$ ) and  $B_{i_0}$  has at least eight vertices. We again write  $A$  and  $B$  instead of  $A_{i_0}$  and  $B_{i_0}$ . It can be checked that  $G[A]$  (as well as  $H[A^*]$ ) has a matching covering all the vertices except the end-vertices of  $e_i$  and  $e_j$  for two different pairs  $i, j$  in  $\{2, 3, 4\}$  with  $i \neq j$ , say 2, 3 and 2, 4. Fix a single canonical matching of  $H[A^*]$  avoiding each of these two pairs of vertices, and a single canonical perfect matching of  $H[A^*]$ . Fix a single canonical perfect matching of  $H[B^*]$  (such a perfect matching exists since any of the graphs  $G_{(ij)}^B$  is bridgeless, and thus matching-covered). By Lemma 23 and the observations in the previous cases, one of the graphs  $G_{(12)}^B$ ,  $G_{(13)}^B$ , or  $G_{(14)}^B$  is cyclically 4-edge-connected and all perfect matchings of its expansion avoiding  $e$  can be combined with a canonical matching of  $H[A^*]$ . Hence, the number of combinations of a canonical matching in  $H[A^*]$  and a non-canonical matching in  $H[B^*]$  is at least  $(a+3)n_B/24 - \beta - 1$  by the induction within this lemma (we subtracted one to count the canonical matching).

Observe that there are at least  $2^{\lfloor n_A^G/4 \rfloor}$  perfect matchings in  $G[A]$  containing none of the edges of the cut, where  $n_A^G$  is the number of vertices of  $A$  and these at least

$$\frac{a+3}{24} n_A^G b + 2 \geq \frac{a+3}{24} n_A + 2$$

matchings (the bound follows from the choice of  $\gamma$ ) can be extended by

the canonical matching of  $H[B^*]$ . Subtracting one for a possible canonical matching among these, we obtain that the number of combinations of a non-canonical matching in  $H[A^*]$  and a canonical matching in  $H[B^*]$  is at least  $(a + 3)n_A/24 + 1$ , which together with the bound on the combinations of canonical matchings in  $H[A^*]$  and non-canonical matchings in  $H[B^*]$  yields the desired bound.

Observe that if  $G[A]$  is a ladder with at least  $\gamma$  vertices and  $G[B]$  has less than eight vertices, there are at least

$$\frac{a+3}{24} n_A + 2 \geq \frac{a+3}{24} n - \frac{a+3}{4} b + 2$$

perfect matchings in  $H$ . This includes the case when the whole graph is a ladder.

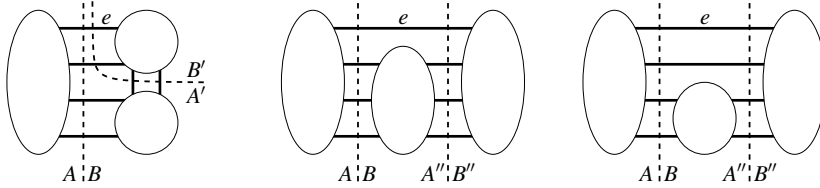

Figure 10: Cyclic 4-edge-cuts containing  $e$  if  $i_0 = k$ .

For the rest of the proof, we can assume  $G[A_{i_0}]$  is a ladder with less than  $\gamma$  vertices. If the number of vertices of  $G$  is less than  $3\gamma$ , then there is nothing to prove by the choice of  $\beta$ .

First, assume that  $i_0 = k$ . We again write  $A$  and  $B$  instead of  $A_{i_0}$  and  $B_{i_0}$ . Let  $E(A, B) = \{e = e_1, e_2, e_3, e_4\}$ . Since  $G[A]$  is a ladder, we may assume there is a (canonical) matching of  $H[A^*]$  covering all vertices except the end-vertices of  $v_i$  and  $v_j$ ,  $\{i, j\} = \{2, 3\}$  or  $\{2, 4\}$ ; and a (canonical) perfect matching of  $H[A^*]$ . Consider the graph  $G' = G_{(12)}^B$ . If there is a cyclic 3-edge-cut  $E(X, Y)$  in  $G'$ , then the new edge  $e_{12}$  is in the cut. Assume that the end-vertex of  $e$  in  $B$  is in  $Y$ . Then  $E(A', B')$  with  $A' = A \cup X \setminus \{v_{34}\}$ ,  $B' = Y \setminus \{v_{12}\}$  is a cyclic 4-edge-cut in  $G$  containing  $e$  such that  $A' \supsetneq A$ , a contradiction (see Figure 10, left). Therefore,  $G'$  is cyclically 4-edge-connected.

If  $G'$  has a cyclic 4-edge-cut  $E(X, Y)$  containing  $e$ , then the new edge  $e_{12}$  is not in the cut. Again, assume that the end-vertex of  $e$  in  $B$  is in  $Y$ . Then

$v_{12}, v_{34} \in X$  and again  $E(A'', B'')$  with  $A'' = A \cup X \setminus \{v_{12}, v_{34}\}$ ,  $B'' = Y$  is a cyclic 4-edge-cut in  $G$  such that  $A'' \supsetneq A$ , a contradiction (see Figure 10, center and right). Therefore, there is no cyclic 4-edge-cut containing  $e$  in  $G$ . Hence, by Lemma D.a.b, the expansion of  $G_{(12)}^B$  has at least

$$\frac{a+3}{24}(n - \gamma b) - \beta_D = \frac{a+3}{24}n - \frac{a+3}{24}\gamma b - \beta_D$$

perfect matchings avoiding  $e$ . As each of these matchings can be extended by a canonical matching of  $H[A^*]$  to a perfect matching of  $H$ , the claim now follows by the choice of  $\beta$ .

Next, assume that  $i_0 < k$ . Then  $G[A_{i_0+1}]$  is not a ladder, thus  $G[B_{i_0+1}]$  has less than 8 vertices or it is a ladder with less than  $\gamma$  vertices. Let  $A = A_{i_0}$ ,  $B = B_{i_0+1}$ ,  $C = V(G) \setminus (A \cup B)$ . We use the following arguments also in the case when for all  $i$  either  $G[A_i]$  or  $G[B_i]$  has less than 8 vertices.

The number of edges between  $A$  and  $B$  is one or two: the edge  $e$  is contained in both  $(A \cup C, B)$  and  $(A, B \cup C)$  and thus it must be joining a vertex of  $A$  and a vertex of  $B$ . On the other hand, if they were three or more edges between  $A$  and  $B$ , then there would be at most two edges between  $A \cup B$  and  $C$  which is impossible since  $G$  is cyclically 4-edge-connected.

Assume now that there are exactly two edges between  $A$  and  $B$ , and let  $e_2$  be the edge distinct from  $e$ . Let  $e_3$  and  $e_4$  be the edges between  $A$  and  $C$  and  $e_5$  and  $e_6$  the edges between  $B$  and  $C$  (see Figure 11, left). Since  $G[A]$  and  $G[B]$  are ladders or have at most 6 vertices, it is easily seen that they both have at least two perfect matchings. We now distinguish three cases (we omit symmetric cases) based on the number  $m_{34}^A$  (and  $m_{56}^B$ ) of matchings in  $G[A]$  ( $G[B]$ ) covering all the vertices but the end-vertices of  $e_3$  and  $e_4$  ( $e_5$  and  $e_6$ , respectively):

- Let  $m_{34}^A \geq 1$  and  $m_{56}^B \geq 1$ . Remove all the vertices of  $A \cup B$  and identify the edges  $e_3$  and  $e_4$  to a single edge and the edges  $e_5$  and  $e_6$  to a single edge. Observe that the resulting graph is bridgeless and thus its expansion contains at least

$$\frac{a+3}{24}(n - 2\gamma b) - \beta_B = \frac{a+3}{24}n - \frac{a+3}{12}\gamma b - \beta_B$$

perfect matchings by Lemma B.a. Each of these matchings can be extended to a perfect matching of  $H$  avoiding  $e$  and the bound follows.

- Let  $m_{34}^A = 0$  and  $m_{56}^B = 0$ . Observe that  $G[A \cup B]$  contains a matching avoiding  $e$  and covering all the vertices except the end-vertices of  $e_3$

or  $e_4$  (the edge can be prescribed) and  $e_5$  or  $e_6$  (again, the edge can be prescribed). To see this, observe that in  $G_{(13)}^A$ , there exists a perfect matching containing  $e_3^A$ . Since  $m_{34} = 0$ , this matching also contains  $e_2^A$ . Similarly, considering perfect matchings of  $G_{(14)}^A$  containing  $e_4^A$  we get that  $G[A]$  has a matching covering all the vertices except the end-vertices of  $e_2$  and  $e_4$ ; and the same holds for  $G[B]$ . The combination of these four matchings yields the desired result.

Remove now all the vertices of  $A \cup B$ , identify the end-vertices of  $e_3$  and  $e_4$  and the end-vertices of  $e_5$  and  $e_6$  and add an edge between the two new vertices. Observe that the resulting graph is bridgeless and thus its expansion contains at least

$$\frac{a+3}{24} (n - 2\gamma b) - \beta_B = \frac{a+3}{24} n - \frac{a+3}{12} \gamma b - \beta_B$$

perfect matchings by Lemma B.a. Each of these matchings can be extended to a perfect matching of  $H$  avoiding  $e$  and the bound follows.

- Let  $m_{34}^A \geq 1$  and  $m_{56}^B = 0$ . Recall that each of  $G[A]$  and  $G[B]$  is a ladder or has at most 6 vertices. Hence, each of them is either the exceptional graph of Figure 8 or bipartite. Hence,  $h_{\emptyset}^A \geq 2$  and  $h_{\emptyset}^B \geq 2$  and therefore there are at least four perfect matchings of  $G[A \cup B]$  avoiding  $e$ .

Observe that in the exceptional graph, all the values  $m_{ij}$  are at least one, so  $G[B]$  is necessarily bipartite. Two of the four corners (vertices of degree two) are white, and two are black. Moreover, there is a matching covering all the vertices except any pair of corners of distinct colors, and there are no matchings covering all the vertices except a pair of corners of the same color. Since  $m_{56}^B = 0$ , the end-vertices of  $e_5$  and  $e_6$  have the same color. Hence, there exist a matching covering all the vertices of  $G[B]$  except  $e_2$  and  $e_5$  (resp.  $e_2$  and  $e_6$ ). Consider perfect matchings of  $G_{(12)}^A$  containing  $e_2^A$ . By symmetry, we may assume there is a matching of  $G[A]$  covering all its vertices except the end-vertices of  $e_2$  and  $e_3$ .

Altogether, these matchings can be combined to matchings of  $G[A \cup B]$  avoiding  $e$  covering all its vertices except:

- the end-vertices of  $e_3$  and  $e_5$ , and
- the end-vertices of  $e_3$  and  $e_6$ , and

- the end-vertices of  $e_3$  and  $e_4$ : such a matching is obtained by combining a perfect matching of  $G[B]$  and a matching of  $G[A]$  covering all the vertices except the end-vertices of  $e_3$  and  $e_4$  (which exists since  $m_{34}^A \geq 1$ .)

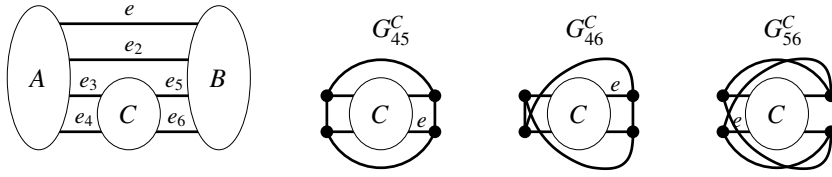

Figure 11: When there are two edges between  $A$  and  $B$ .

Consider now the graphs  $G_{ij}^C$ ,  $\{i, j\} \subseteq \{4, 5, 6\}$  obtained from  $G$  by removing all the vertices of  $A \cup B$ , introducing a new cycle of length four and making its vertices incident with the edges  $e_i, e_3, e_j$  and the remaining edge which will play the role of  $e$  (in this order). These three graphs are depicted in Figure 11, right. Applying Lemma E.(a-1).b to the three graphs  $G_{ij}^C$ , we obtain the following inequalities:

$$\begin{aligned} h_{34}^C + h_{35}^C + 2h_{\emptyset}^C &\geq \frac{a+2}{24} (n - 2\gamma b) - \beta_E \\ h_{34}^C + h_{36}^C + 2h_{\emptyset}^C &\geq \frac{a+2}{24} (n - 2\gamma b) - \beta_E \\ h_{35}^C + h_{36}^C + 2h_{\emptyset}^C &\geq \frac{a+2}{24} (n - 2\gamma b) - \beta_E \end{aligned}$$

where  $h_X^C$  is the number of matchings of the expansion of  $G[C]$  covering all its vertices except the end-vertices of the edges with indices from  $X$ . Observe that perfect matchings of  $G_{ij}^C$  avoiding  $e$  can be extended to perfect matchings of  $H$  (avoiding the original  $e$ ); those avoiding all the four edges incident with the cycle in at least four different ways. Finally, we obtain the following estimate on the number of perfect matchings of  $H$  avoiding  $e$ :

$$\begin{aligned} h_{34}^C + h_{35}^C + h_{36}^C + 4h_{\emptyset}^C &\geq \frac{3}{2} \cdot \left[ \frac{a+2}{24} n - \frac{a+2}{12} \gamma b - \beta_E \right] \\ &\geq \frac{a+3}{24} n - \frac{a+2}{8} \gamma b - \frac{3}{2} \beta_E. \end{aligned}$$

It remains to consider the case that the edge  $e$  is the only edge between  $A$  and  $B$ . Let  $e_2, e_3$  and  $e_4$  be the three edges between  $A$  and  $C$ , and  $e'_2,$

$e'_3$  and  $e'_4$  the three edges between  $B$  and  $C$  (see Figure 12, left). Recall that each of  $G[A]$  and  $G[B]$  is a ladder or has at most six vertices. By symmetry, we can assume that, in addition to a perfect matching,  $G[A]$  contains a matching covering all its vertices except the end-vertices of  $e_2$  and one of the edges  $e_3$  and  $e_4$  (both choices possible). Symmetrically, for  $G[B]$ . Remove now all the vertices of  $A \cup B$ , identify the end-vertices of  $e_3$  and  $e_4$  and join the new vertex to the end-vertex of  $e_2$ . Symmetrically, for  $e'_2, e'_3$  and  $e'_4$ . Finally, let  $e$  be the edge joining the only two vertices of degree two (see Figure 12, center). It can be verified that the resulting graph  $G'$  is cyclically 4-edge-connected and  $e$  is not in any cyclic 4-edge-cut of it unless  $e$  is contained in a triangle in  $G'$ . Hence, unless  $e$  is contained in a triangle in  $G'$ , by Lemma D.a.b the expansion of  $G'$  has at least

$$\frac{a+3}{24} (n - 2\gamma b) - \beta_D = \frac{a+3}{24} n - \frac{a+3}{12} \gamma b - \beta_D$$

perfect matchings avoiding  $e$  which all extend to the expansion of  $G$ .

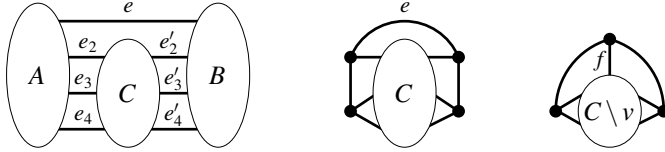

Figure 12: When there is only one edge between  $A$  and  $B$ .

Assume now that  $e$  is contained in a triangle. In other words, the edges  $e_2$  and  $e'_2$  have a common vertex, say  $v$ , in  $G$  and let  $f$  be the third edge incident with  $v$ . Observe that  $G'$  is 2-almost cyclically 4-edge-connected (its only cyclic 3-edge-cut is the triangle containing  $e$ ). Reduce the triangle (see Figure 12, right) and apply Lemma E.(a-1).b. Observe that each matching of the expansion of the reduced graph avoiding  $f$  can be extended in at least two different ways to a perfect matching of  $H$  avoiding  $e$  (for any such matching, either none of the edges of  $E(A, B \cup C)$  is included and we use  $h_{\mathcal{D}}^A \geq 2$ , or none of the edges of  $E(A \cup C, B)$  is included and we use  $h_{\mathcal{D}}^B \geq 2$ ). Hence, the number of perfect matchings of  $H$  avoiding  $e$  is at least

$$2 \cdot \frac{a+2}{24} (n - 2\gamma b - 2b) - 2\beta_E \geq \frac{a+3}{24} n - \frac{a+2}{6} (\gamma + 1)b - 2\beta_E.$$

□

This finishes the proof of the E-series of the lemmas and also concludes the proof of Theorem 1, which is readily seen to be a direct consequence of the B-series. Note that from the E-series we obtain the following result:

**Theorem 32.** *For any  $\alpha > 0$  there exists a constant  $\beta > 0$  such that every  $n$ -vertex cyclically 4-edge-connected cubic graph has at least  $\alpha n - \beta$  perfect matchings avoiding any given edge.*

This does not hold for 3-edge-connected graphs: there exists an infinite family of 3-edge-connected cubic graphs containing an edge avoided by only two perfect matchings. However, recall that by Lemma 18, any 3-edge-connected cubic graph has a linear number of perfect matchings avoiding any edge not contained in a cyclic 3-edge-cut.

Despite all our efforts, we were not able to replace the bound in Theorem 1 by an explicit superlinear bound. We offer 1 kg of chocolate bars *Studentská pečet'* for the first explicit bound derived from our proof. To get a superpolynomial or even an exponential bound, one would probably like to insert Lemma 18 in the induction argument; we believe that the linear bound in Lemma 18 can be replaced by a bound exponential in  $n$ .

## References

- [1] M. Chudnovsky, P. Seymour: Perfect matchings in planar cubic graphs, *Combinatorica*, in press.
- [2] J. Edmonds: Maximum matching and a polyhedron with  $(0, 1)$  vertices, *J. Res. Nat. Bur. Standards Sect B* **69B** (1965), 125–130.
- [3] J. Edmonds, L. Lovász, W. R. Pulleyblank: Brick decompositions and the matching rank of graphs, *Combinatorica* **2** (1982), 247–274.
- [4] L. Esperet, D. Král', P. Škoda, R. Škrekovski: An improved linear bound on the number of perfect matchings in cubic graphs, *European J. Combin.*, in press.
- [5] D. Král', J.-S. Sereni, M. Stiebitz: A new lower bound on the number of perfect matchings in cubic graphs, *SIAM J. Discrete Math.* **23** (2009), 1465–1483.

- [6] L. Lovász: Matching structure and the matching lattice, *J. Combin. Theory Ser. B* **43** (1987), 187–222.
- [7] L. Lovász, M. D. Plummer: *Matching theory*, Elsevier Science, Amsterdam, 1986.
- [8] D. Naddef: Rank of maximum matchings in a graph, *Math. Programming* **22** (1982), 52–70.
- [9] S. Oum: Perfect matchings in claw-free cubic graphs, submitted (2009), arXiv:0906.2261v2 [math.CO].
- [10] J. Petersen: Die Theorie der regulären graphs, *Acta Math.* **15** (1891), 193–220.
- [11] J. Plesník: Connectivity of regular graphs and the existence of 1-factors. *Mat. Časopis Slovens. Akad. Vied* **22** (1972), 310–318.
- [12] M. Voorhoeve: A lower bound for the permanents of certain  $(0, 1)$ -matrices, *Nederl. Akad. Wetensch. Indag. Math.* **41** (1979), 83–86.