

3-choosability of triangle-free planar graphs with constraint on 4-cycles*

Zdeněk Dvořák[†] Bernard Lidický[‡] Riste Škrekovski[§]

Abstract

A graph is k -choosable if it can be colored whenever every vertex has a list of at least k available colors. A theorem by Grötzsch [2] asserts that every triangle-free planar graph is 3-colorable. On the other hand Voigt [10] gave such a graph which is not 3-choosable. We prove that every triangle-free planar graph such that 4-cycles do not share edges with other 4- and 5-cycles is 3-choosable. This strengthens the Thomassen's result [8] that every planar graph of girth at least 5 is 3-choosable. In addition, this implies that every triangle-free planar graph without 6- and 7-cycles is 3-choosable.

1 Introduction

All graphs considered in this paper are simple and finite. The concepts of list coloring and choosability were introduced by Vizing [9] and independently by Erdős et al. [1]. A *list assignment* of G is a function L that assigns to each vertex $v \in V(G)$ a list $L(v)$ of available colors. An L -*coloring* is a function $\varphi : V(G) \rightarrow \bigcup_v L(v)$ such that $\varphi(v) \in L(v)$ for every $v \in V(G)$

*Supported by a CZ-SL bilateral project MEB 090805 and BI-CZ/08-09-005.

[†]Department of Applied Mathematics, Faculty of Mathematics and Physics, Charles University, Malostranské náměstí 25, 118 00 Prague, Czech Republic. E-mail: rakdver@kam.mff.cuni.cz. Partially supported by Institute for Theoretical Computer Science (ITI), project 1M0021620808 of Ministry of Education of Czech Republic.

[‡]Department of Applied Mathematics, Faculty of Mathematics and Physics, Charles University, Malostranské náměstí 25, 118 00 Prague, Czech Republic. E-mail: bernard@kam.mff.cuni.cz.

[§]Department of Mathematics, University of Ljubljana, Jadranska 19, 1111 Ljubljana, Slovenia. Partially supported by Ministry of Science and Technology of Slovenia, Research Program P1-0297.

and $\varphi(u) \neq \varphi(v)$ whenever u and v are adjacent vertices of G . If G admits an L -coloring, then it is L -colorable. A graph G is k -choosable if it is L -colorable for every list assignment L such that $|L(v)| \geq k$ for all $v \in V(G)$. Cycles C_1 and C_2 in a graph are *adjacent* if they intersect in a single edge, i.e., if $V(C_1) \cap V(C_2) = \{u, v\}$ for an edge uv .

Thomassen [7, 8] proved that every planar graph is 5-choosable, and every planar graph of girth at least 5 is 3-choosable. Kratochvíl and Tuza [3] observed that every planar triangle-free graph is 4-choosable. On the other hand, Voigt [10, 11] found a planar graph that is not 4-choosable, and a triangle-free planar graph that is not 3-choosable. Numerous papers study additional conditions that force a triangle-free planar graph to be 3-choosable, see e.g. [4, 6, 12, 13, 14, 15].

In particular, let us point out the result of Li [5], strengthening the result of Thomassen [8]: every planar triangle-free graph such that no 4-cycle shares a **vertex** with another 4- or 5-cycle is 3-choosable. We further improve this result, only forbidding the 4-cycles sharing an **edge** with other 4- or 5-cycles:

Theorem 1. *Any planar triangle-free graph without 4-cycles adjacent to 4- and 5-cycles is 3-choosable.*

In particular, we obtain:

Corollary 2. *Any planar graph without 3-, 6- and 7-cycles is 3-choosable.*

This strengthens the results of Lidický [6] that planar graphs without 3-, 6-, 7- and 8-cycles are 3-choosable, and of Zhang and Xu [13] that planar graphs without 3-, 6-, 7- and 9-cycles are 3-choosable. Theorem 1 also implies the result of Lam et al. [4] that planar graphs without 3, 5 and 6-cycles are 3-choosable.

2 Proof of Theorem 1

A *path of length k* (or a *k -path*) is a path on $k + 1$ vertices. Using the proof technique of precoloring extension developed by Thomassen [8], we show the following extension of Theorem 1:

Theorem 3. *Let G be a triangle-free planar graph without 4-cycles adjacent to 4- and 5-cycles, with outer face C , and P a path of length at most three such that $V(P) \subseteq V(C)$. The graph G can be L -colored for any list assignment L such that*

- $|L(v)| = 3$ for all $v \in V(G) \setminus V(C)$;
- $2 \leq |L(v)| \leq 3$ for all $v \in V(C) \setminus V(P)$;
- $|L(v)| = 1$ for all $v \in V(P)$, and the colors in the lists give a proper coloring of the subgraph of G induced by $V(P)$;
- the vertices with lists of size two form an independent set; and
- each vertex with lists of size two has at most one neighbor in P .

Note that we view the single-element lists as a precoloring of the vertices of P . Also, P does not have to be a part of the facial walk of C , as we only require $V(P) \subseteq V(C)$. Theorem 3 has the following easy consequence:

Corollary 4. *Let G be a triangle-free planar graph without 4-cycles adjacent to 4- and 5-cycles, with the outer face bounded by an induced cycle C of length at most 9. Furthermore, assume that*

- if $\ell(C) = 8$, then at least one edge of C does not belong to a 4-cycle; and
- if $\ell(C) = 9$, then some two consecutive edges of C do not belong to 4- and 5-cycles.

Let L be an assignment of lists of size 1 to the vertices of C and lists of size 3 to the other vertices of G . If L prescribes a proper coloring of C , then G can be L -colored.

Proof. The claim follows from Theorem 3 for $\ell(C) = 4$. If $\ell(C) \in \{5, 6, 7\}$, then let $u_1w_1vw_2u_2$ be an arbitrary subpath of C . Let L' be the list assignment obtained from L by removing the color $L(v)$ from the lists of vertices adjacent to v . We also set the lists of w_1 and w_2 to 2-lists such that the precoloring of the other vertices of C forces the prescribed color $L(w_1)$ on w_1 and $L(w_2)$ on w_2 , i.e., $L'(w_1) = L(w_1) \cup L(u_1)$ and $L'(w_2) = L(w_2) \cup L(u_2)$. As all the vertices x with $|L'(x)| = 2$ are neighbors of a single vertex v , the graph $G - v$ together with the list assignment L' satisfies the assumptions of Theorem 3. It follows that we can L' -color $G - v$, giving an L -coloring of G .

Let us now consider the case that $\ell(C) = 8$, and let $C = w_1uvw_2r_1r_2r_3r_4$, where the edge uv does not belong to a 4-cycle. Let us delete vertices u and v from G , remove the color in $L(u)$ from the lists of neighbors of u and the

color in $L(v)$ from the lists of neighbors of v , and change the list of w_1 to $L(w_1) \cup L(r_4)$ and the list of w_2 to $L(w_2) \cup L(r_1)$, so that the precoloring of the path $P = r_1r_2r_3r_4$ forces the right colors on w_1 and w_2 . As uv does not belong to a 4-cycle, the vertices with lists of size two form an independent set. As C is induced, both w_1 and w_2 have only one neighbor in the 3-path P . Let x be a neighbor of u other than v and w_1 . The vertex x cannot be adjacent to both r_1 and r_4 , as the 4-cycle uxr_4w_1 would be adjacent to a 5-cycle $xr_1r_2r_3r_4$. Similarly, x cannot be adjacent to both r_1 and r_3 or both r_2 and r_4 . As G does not contain triangles, x has at most one neighbor in P . By symmetry, this is also true for the neighbors of v . Therefore, the graph satisfies assumptions of Theorem 3, and can be colored from the prescribed lists.

Finally, suppose that $\ell(C) = 9$, and let $C = w_1uvw_2r_1r_2r_3r_4$, where the edges uv and vw are not incident with 4- and 5-cycles. We argue similarly as in the previous case. We delete vertices u , v and w from G and remove their colors from the lists of their neighbors. We also set the list of w_1 to $L(w_1) \cup L(r_4)$ and the list of w_2 to $L(w_2) \cup L(r_1)$, so that the precoloring of the path $r_1r_2r_3r_4$ forces the right colors on w_1 and w_2 . Observe that the resulting graph satisfies assumptions of Theorem 3, hence it can be colored. \square

Before we proceed with the proof of Theorem 3, let us describe the notation that we use in figures. We mark the precolored vertices of P by full circles, the vertices with list of size three by empty circles, and the vertices with list of size two by empty squares. The vertices for that the size of the list is not uniquely determined in the situation demonstrated by the particular figure are marked by crosses.

Proof of Theorem 3. Suppose G together with lists L is the smallest counterexample, i.e., such that $|V(G)| + |E(G)|$ is minimal among all graphs that satisfy the assumptions of Theorem 3, but cannot be L -colored, and $\sum_{v \in V(G)} |L(v)|$ is minimal among all such graphs. Let C be the outer face of G and P a path with $V(P) \subseteq V(C)$ as in the statement of the theorem. We first derive several properties of this counterexample. Note that each vertex v of G has degree at least $|L(v)|$.

Lemma 5. *The graph G does not contain separating cycles of length at most seven. Every edge of each separating 8-cycle K belongs to a 4-cycle lying inside K . And, at least one of every two consecutive edges of each separating 9-cycle K belongs to a 4- or 5-cycle lying inside K .*

Proof. Let K be the separating cycle. We may assume that K is induced, as otherwise we could consider a shorter separating cycle of length at most 7. Let G_1 be the subgraph of G induced by the exterior of K (including K) and G_2 the subgraph of G induced by the interior of K (including K). By the minimality of G , Theorem 3 holds for G_1 and G_2 and their subgraphs. Therefore, there exists a coloring of G_1 from the prescribed lists, and this coloring can be extended to G_2 by Corollary 4. This is a contradiction, as G cannot be colored from the lists. \square

A *chord* of a cycle K is an edge in G joining two distinct vertices of K that are not adjacent in K . As G does not have triangles and 4-cycles adjacent to 4- and 5-cycles, a cycle of length at most 7 does not have a chord. Therefore, Lemma 5 implies that every cycle of length at most 7 is a face. Similarly, a cycle K of length 8 with an edge that does not belong to a 4-cycle in the interior of K is either an 8-face, or it has a chord splitting it to a 4-face and a 6-face, or two 5-faces.

Lemma 6. *The graph G is 2-connected.*

Proof. Obviously, G is connected. Suppose now that v is a cut vertex of G and G_1 and G_2 are nontrivial induced subgraphs of G such that $G = G_1 \cup G_2$ and $V(G_1) \cap V(G_2) = \{v\}$. Both G_1 and G_2 satisfy the assumptions of Theorem 3. If v is precolored, then by the minimality of G there exist L -colorings of G_1 and G_2 , and they combine to a proper L -coloring of G . If v is not precolored, then we may assume that $P \subseteq G_1$. An L -coloring of G_1 assigns a color c to v . We change the list of v to $\{c\}$, color G_2 and combine the colorings to an L -coloring of G . \square

By Lemma 6, C is a cycle. A k -*chord* of C is a path $Q = q_0q_1 \dots q_k$ of length k joining two distinct vertices of C , such that $V(C) \cap V(Q) = \{q_0, q_k\}$ (e.g., 1-chord is just a chord).

Lemma 7. *The cycle C has no chords.*

Proof. Suppose $e = uv$ is a chord of C , separating G to two subgraphs G_1 and G_2 intersecting in e . If both u and v are precolored, then we L -color G_1 and G_2 by the minimality of G and combine their colorings. Otherwise, by symmetry assume that $u \notin V(P)$, and that $|V(P) \cap V(G_1)| \geq |V(P) \cap V(G_2)|$. In particular, $|(V(P) \cap V(G_2)) \setminus \{u, v\}| \leq 1$. Furthermore, let us choose the chord in such a way that G_2 is as small as possible; in

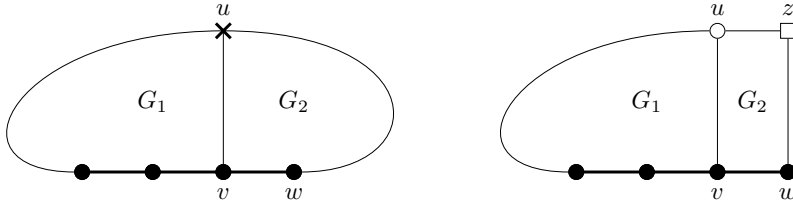

Figure 1: A chord of C

particular, the outer face of G_2 does not have a chord. Let us find an L -coloring of G_1 and change the lists of u and v to the colors assigned to them. If G_2 with these new lists satisfies assumptions of Theorem 3, then we find its coloring and combine the colorings to an L -coloring of G , hence assume that this is not the case.

Let $X = (V(P) \cap V(G_2)) \setminus \{u, v\}$. As G_2 does not satisfy assumptions of Theorem 3, there exists a vertex z with list of size two adjacent to two precolored vertices. As G is triangle-free, we conclude that X is not empty, say $X = \{w\}$ (see Figure 1), and z is adjacent to u and w . As G_2 does not contain chords and separating 4-cycles and $z \in V(C)$, G_2 is equal to the cycle $uvwz$. Since $|L(z)| = 2$, it holds that $|L(u)| = 3$. Let c_1 be the color of u in the coloring of G_1 , and c_2 the single color in the list of w . If $L(z) \neq \{c_1, c_2\}$, then we can color z and finish the coloring of G , hence assume that $L(z) = \{c_1, c_2\}$. Let c be a color in $L(u) \setminus (\{c_1\} \cup L(v))$ (this set is nonempty, as $|L(v)| = 1$ and $|L(u)| = 3$).

Let us now color z by c_1 and set the list of u to $\{c\}$. If G_1 with this list at u satisfies assumptions of Theorem 3, we can color G_1 , and thus obtain an L -coloring of G . Since G does not have such an L -coloring, the assumptions are violated, i.e., either u is adjacent to a vertex of P other than v , or G_1 contains a vertex (with list of size two) adjacent to both u and a vertex of P . This is a contradiction, as G would in both of these cases contain either a triangle, or a 4- or 5-cycle adjacent to the 4-cycle $uvwz$. \square

By the previous lemma, P is a part of the facial walk of C , and C is an induced cycle.

Lemma 8. $\ell(C) \geq 8$.

Proof. Suppose that $\ell(C) \leq 7$. If $V(C) \neq V(P)$, then color the vertices of C properly from their lists. This can be done, as C is chordless and

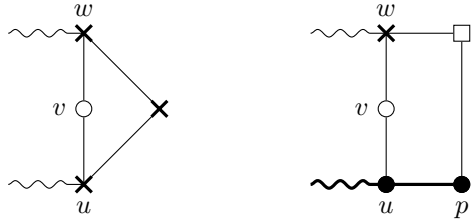

Figure 2: Possible 2-chords in G

contains at least one vertex with list of size three. If $5 \leq \ell(C) \leq 7$, then the claim follows from the proof of Corollary 4, as by the minimality of G , all subgraphs of G satisfy Theorem 3. If $\ell(C) = 4$, then we delete one of the vertices of C and remove its color from the lists of its neighbors. It is easy to verify that the resulting graph satisfies the assumptions of Theorem 3, hence it has a proper coloring by the minimality of G . This coloring extends to an L -coloring of G , which is a contradiction. \square

Lemma 9. *No 4-cycle shares an edge with another 4- or 5-cycle.*

Proof. Suppose that $C_1 = v_1v_2v_3v_4$ and $C_2 = v_1v_2u_3 \dots u_t$ are cycles sharing the edge v_1v_2 , $\ell(C_1) = 4$ and $t = \ell(C_2) \in \{4, 5\}$. Note that $C_1 \neq C$ and $C_2 \neq C$ by Lemma 8. By Lemma 5, both C_1 and C_2 bound a face. If $v_3 = u_3$, then v_2 would be a 2-vertex with list of size three. Thus, $v_3 \neq u_3$ and by symmetry, $v_4 \neq u_t$. As G does not contain triangles, $v_3 \neq u_t$ and $v_4 \neq u_3$, and in case that $t = 5$, $v_3 \neq u_4$ and $v_4 \neq u_4$. Therefore, C_1 and C_2 are adjacent, contradicting the assumptions of Theorem 3. \square

Note that we can assume that $|V(P)| = 4$, as otherwise we can prescribe color for more of the vertices of C , without violating assumptions of Theorem 3. Let $P = p_1p_2p_3p_4$. We say that a k -chord Q of C *splits off* a face F from G if $F \neq C$ is a face of both G and $C \cup Q$. See Figure 2 for an illustration of 2-chords splitting off a face.

Lemma 10. *Every 2-chord uvw of C splits off a k -face F such that*

- (a) $|V(F) \cap V(P)| \leq 2$ and $\{u, w\} \not\subseteq V(P)$,
- (b) $k \leq 5$, and

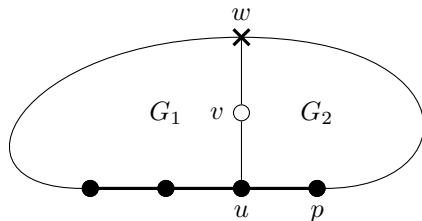

Figure 3: A 2-chord of C

(c) if $|V(F) \cap V(P)| \leq 1$, then $k = 4$.

In particular, the cycle C has no 2-chord with $|L(w)| = 2$ and $u \neq p_2, p_3$.

Proof. Suppose first that $u, w \in V(P)$. By Lemma 5, the 2-chord uvw together with a part of P bounds a face K . Color v by a color different from the colors of u and w , and remove $V(K) \setminus \{u, v, w\}$ from G , obtaining a graph G' . Note that a path of length at most three is precolored in G' . Since G cannot be L -colored, we may assume that G' does not satisfy assumptions of Theorem 3, i.e., there exists z with $|L(z)| = 2$ adjacent to both v and a vertex $y \in V(P) \cap V(G')$. As G is triangle-free, $y \notin \{u, w\}$. It follows that $yuvz$ or $ywvz$ is a 4-face. This is a contradiction, as K would be an adjacent 4-face. Therefore, $\{u, w\} \not\subseteq V(P)$, and by symmetry we assume that $w \notin V(P)$.

The 2-chord uvw splits G to two subgraphs G_1 and G_2 intersecting in uvw . Let us choose G_2 such that $|V(P) \cap V(G_2)| \leq |V(P) \cap V(G_1)|$, see Figure 3. Note that $|V(P) \cap V(G_2)| \leq 2$. Let us consider the 2-chord uvw such that $|V(P) \cap V(G_2)|$ is minimal, subject to the assumption that G_2 is not a face. By the minimality of G , there exists an L -coloring φ of G_1 . Let L' be the list assignment for G_2 such that $L'(u) = \{\varphi(u)\}$, $L'(v) = \{\varphi(v)\}$, $L'(w) = \{\varphi(w)\}$ and $L'(x) = L(x)$ for $x \in V(G_2) \setminus \{u, v, w\}$. Let P' be the precolored path in G_2 (consisting of u, v, w , and possibly one other vertex p of P adjacent to u). As C has no chords and G_2 is not a face, P' is an induced subgraph. Since G cannot be L -colored, we conclude that G_2 cannot be L' -colored, and thus G_2 with the list assignment L' does not satisfy the assumptions of Theorem 3. Therefore, there exists a vertex z with $|L(z)| = 2$, adjacent to two vertices of P' .

Since G_2 is not a face, Lemmas 5 and 7 imply that z is not adjacent to both w and p . Similarly, z is not adjacent to both u and w . It follows that z is adjacent to v and p , and thus $|V(P) \cap V(G_2)| = 2$. Since we have chosen the 2-chord uvw so that $|V(P) \cap V(G_2)| = 2$ is minimal among the 2-chords for that G_2 is not a face, the 2-chord wvz splits off a face F' from G . Let x be the neighbor of z in F' other than v . Since $|L(z)| = 2$, it holds that $|L(x)| = 3$. As F' is a face, $\deg(x) = 2$, which is a contradiction. It follows that for every 2-chord, G_2 is a face. The choice of G_2 establishes (a).

Let $wvuv_4 \dots v_k$ be the boundary of the face G_2 . Note that $V(P) \cap V(G_2) \subseteq \{u, v_4\}$, and v_4, \dots, v_k have degree two. If $k > 5$, then at least one of v_5 and v_6 has list of size three, which is a contradiction, proving (b). Similarly, if $|V(F) \cap V(P)| \leq 1$ and $k = 5$, then at least one of v_4 and v_5 would be a 2-vertex with list of size three, proving (c).

Consider now a 2-chord uvw such that $|L(w)| = 2$ and $u \notin \{p_2, p_3\}$, and let x be the neighbor of w in G_2 distinct from v . As $u \notin \{p_2, p_3\}$, no vertex of $V(P) \setminus \{u\}$ lies in G_2 . Therefore, $|L(x)| = 3$ and $\deg(x) = 2$, a contradiction. We conclude that no such 2-chord exists. \square

Let us now consider the 3-chords of C :

Lemma 11. *Every 3-chord $Q = uvwx$ of C such that $u, x \notin \{p_2, p_3\}$ splits off a 4- or 5-face.*

Proof. Suppose that Q splits G into two subgraphs G_1 and G_2 intersecting in uvw , such that $V(P) \cap V(G_2) \subseteq \{u, x\}$. Let us L -color G_1 and consider the vertices u, v, w and x of G_2 as precolored according to this coloring. If ux were an edge, then Q would split off a 4-face. It follows that Q is an induced path thus this precoloring of Q is proper. Similarly, as Q does not split off a 5-face, u and x do not have a common neighbor with list of size two. Neither v nor w is adjacent to a vertex with list of size 2 by Lemma 10. Therefore, G_2 satisfies assumptions of Theorem 3, and the coloring can be extended to G_2 , giving an L -coloring of G . This is a contradiction. \square

Let $x_1x_2x_3x_4$ be the part of the facial walk of C such that x_1 is adjacent to p_4 and $x_2 \neq p_4$. By Lemma 8, $\{x_1, x_2, x_3, x_4\} \cap V(P) = \emptyset$. Let us now show a few properties of the vertices x_1, x_2, x_3, x_4 and their neighbors.

Lemma 12. *Let $Q = v_0v_1 \dots v_k$ be a k -chord starting and ending in vertices of $x_1x_2x_3x_4$, or a cycle intersecting C in a single vertex $x \in \{x_1, x_2, x_3, x_4\}$. The following holds (for some $i \in \{1, 2, 3, 4\}$):*

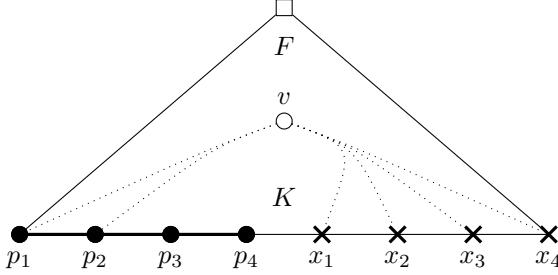

Figure 4: A 2-chord from p_1 or p_2 to $\{x_1, x_2, x_3, x_4\}$

- If $\ell(Q) = 2$, then $Q = x_i v_1 x_{i+2}$ splits off a 4-face.
- If $\ell(Q) = 3$, then Q splits off either a 4-face $x_i x_{i+1} v_1 v_2$, or a 5-face $x_i x_{i+1} x_{i+2} v_1 v_2$.
- If $\ell(Q) = 4$, then Q forms a boundary of a 4-face $x_i v_1 v_2 v_3$, or splits off a 5-face $x_i x_{i+1} v_1 v_2 v_3$, or splits off a 6-face $x_i x_{i+1} x_{i+2} v_1 v_2 v_3$.

Proof. By a simple case analysis. The details are left to the reader. \square

Note also that if Q splits off a face of form $x_i x_{i+1} x_{i+2} v_1 \dots v_{k-1}$, then $\deg(x_{i+1}) = |L(x_{i+1})| = 2$.

Lemma 13. *If Q is a k -chord with $k \leq 3$, starting in a vertex x_i (where $1 \leq i \leq 4$) and ending in a vertex with list of size two, then $k = 3$ and Q bounds a 4-face.*

Proof. Let $Q = q_0 q_1 \dots q_k$, where $q_0 \in \{x_1, x_2, x_3, x_4\}$ and $|L(q_k)| = 2$. By Lemmas 7 and 10, $k > 2$. If $k = 3$, then by Lemma 11, Q splits off a 4- or 5-face. However, the latter is impossible, as $|L(q_3)| = 2$, so the remaining vertex of the 5-face, whose degree is two, would have a list of size three. \square

Lemma 14. *There is no 2-chord from $\{p_1, p_2\}$ to $\{x_1, x_2, x_3, x_4\}$.*

Proof. Suppose $Q = p_i v x_j$ is such a 2-chord, and let K be the cycle formed by Q and $p_i \dots p_4 x_1 \dots x_j$. Note that $\ell(K) \leq 9$. Let us choose Q such that $\ell(K)$ is minimal. By Lemma 10, Q splits off a face F such that $\ell(F) \leq 5$. Furthermore, if $\ell(K) = 9$, then $i = 1$, and hence $|V(P) \cap V(F)| = 1$. In

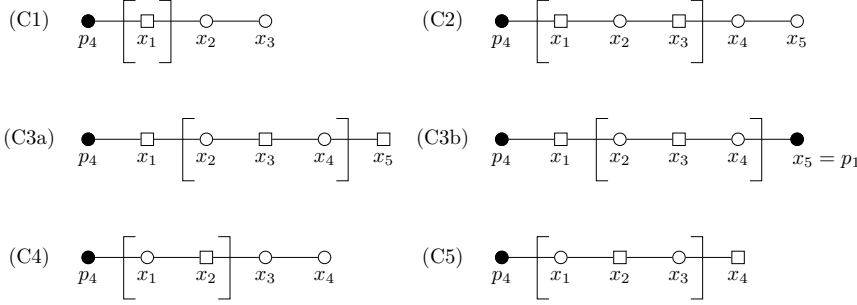

Figure 5: The construction of the set X_1

that case, the claim (c) of Lemma 10 implies $\ell(F) = 4$. See Figure 4 for illustration. It follows that the edges $p_i v$ and $v x_j$ are not incident with a 4-face inside K , and if $\ell(K) = 9$, then they are not incident with a 5-face. By Lemma 5, K is not separating. If $\ell(K) \leq 7$, then K is a face, and $\deg(v) = 2$, which is a contradiction. Similarly, if $\ell(K) > 7$, then K has a chord incident with v . By the minimality of $\ell(K)$, v is adjacent to p_3 or p_4 . However, this contradicts Lemma 10(a). \square

If both x_1 and x_2 have lists of size three, then we remove one color from $L(x_1)$ and find a coloring by the minimality of L (note that x_1 is not adjacent to any vertex with list of size two, and has only one neighbor in P , as C does not have chords). Therefore, exactly one of x_1 and x_2 has a list of size two. Let x_5 be the neighbor of x_4 in C distinct from x_3 . We now distinguish several cases depending on the lists of vertices in $\{x_1, x_2, x_3, x_4\}$, in order to choose a set $X_1 \subseteq \{x_1, x_2, x_3, x_4\}$ of vertices that we are going to color (and remove).

- (C1) If $|L(x_1)| = 2$ and $|L(x_2)| = |L(x_3)| = 3$ (see Figure 5(1)), then we set $X_1 = \{x_1\}$.
- (C2) If $|L(x_1)| = 2$, $|L(x_2)| = 3$, $|L(x_3)| = 2$, $|L(x_4)| = 3$ and $|L(x_5)| = 3$ (see Figure 5(2)), then we set $X_1 = \{x_1, x_2, x_3\}$.
- (C3) If $|L(x_1)| = 2$, $|L(x_2)| = 3$, $|L(x_3)| = 2$, $|L(x_4)| = 3$ and $|L(x_5)| \leq 2$ (see Figure 5(3)), then we set $X_1 = \{x_2, x_3, x_4\}$.
- (C4) If $|L(x_1)| = 3$, $|L(x_2)| = 2$, $|L(x_3)| = 3$ and $|L(x_4)| = 3$ (see Figure 5(4)), then we set $X_1 = \{x_1, x_2\}$.

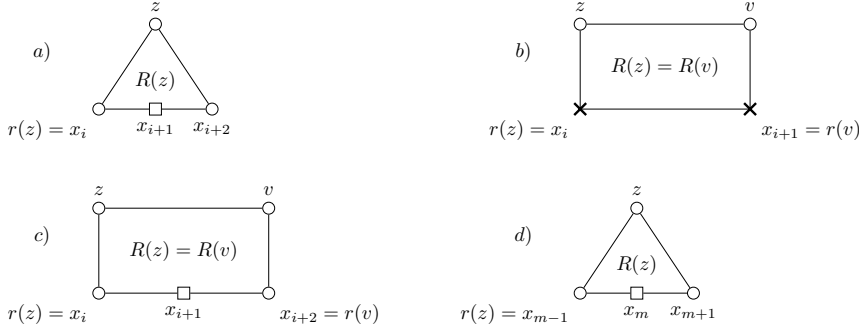

Figure 6: The construction of the set X_2

(C5) If $|L(x_1)| = 3$, $|L(x_2)| = 2$, $|L(x_3)| = 3$ and $|L(x_4)| = 2$ (see Figure 5(5)), then we set $X_1 = \{x_1, x_2, x_3\}$.

Let $m = \max\{i : x_i \in X_1\}$. Note the following properties of the set X_1 :

- $|X_1| \leq 3$.
- If $|L(x_m)| = 2$, then $m \leq 3$ and $|L(x_{m+1})| = |L(x_{m+2})| = 3$.
- If $|L(x_m)| = 3$, then $|L(x_{m+1})| \leq 2$.

Let \mathcal{F} be the set of faces of G incident with the edges of the path induced by X_1 ($\mathcal{F} = \emptyset$ in the case (C1)). We define a set $X_2 \subseteq V(G) \setminus V(C)$, together with functions $r : X_2 \rightarrow X_1$ and $R : X_2 \rightarrow \mathcal{F}$. A vertex $z \in V(G) \setminus V(C)$ belongs to X_2 if

- z is adjacent to two vertices in X_1 (see Figure 6(a) for an example). By Lemma 12, z lies in a (uniquely determined) 4-face $F = x_i x_{i+1} x_{i+2} z$, where $x_i, x_{i+1}, x_{i+2} \in X_1$. We define $r(z) := x_i$ and $R(z) := F$. Or,
- there exists a path $xzvy$ such that $x, y \in X_1$ and $v \notin \{p_1\} \cup X_1$ (see Figure 6(b), (c) and (d) for examples). If $v = x_{m+1}$, then by Lemma 10, the 2-chord xzv splits off a 4-face F . Otherwise the 3-chord $xzvy$ splits off a 4- or 5-face F by Lemma 12. We define $r(z) := x$ and $R(z) := F$. Note that $v \neq x_1$: otherwise, $x_1 \notin X_1$ and we are in case (C3), hence $|L(x_1)| = 2$ and the 2-chord x_1zx would contradict Lemma 10. It follows that v also belongs to X_2 , unless $v = x_{m+1}$.

Let us now show that $r(z)$ and $R(z)$ are well-defined. As a 4-face cannot be adjacent to a 4- or 5-face and G is triangle-free, z does not have another neighbor in X_1 . Also, if there existed another path $xzv'y'$ with $y' \in X_1$ splitting off a face F' , then both F and F' would be 5-faces; however, that would imply $|X_1| \geq 5$, which is a contradiction. Therefore, r and R are defined uniquely. Furthermore, v is the only neighbor of z in X_2 , and $R(v) = R(z)$ (assuming that $v \neq x_{m+1}$).

We now find an L -coloring of $X_1 \cup X_2$ that we aim to extend to a coloring of G .

Lemma 15. *Let $H = G[V(P) \cup X_1 \cup X_2]$ be the subgraph of G induced by $V(P) \cup X_1 \cup X_2$. There exist an L -coloring φ_1 of X_1 and an L -coloring φ_2 of X_2 such that*

- *the coloring of H given by φ_1 , φ_2 and the precoloring of P is proper,*
- *if $|L(x_{m+1})| \leq 2$, then $\varphi_1(x_m) \notin L(x_{m+1})$,*
- *if $x_1 \notin X_1$ (i.e., in the case (C3) of the definition of X_1), then $L(x_1) \neq L(p_4) \cup \{\varphi_1(x_2)\}$, and*
- *if $z \in X_2$ is adjacent to x_{m+1} , then $|L(x_{m+1}) \setminus \{\varphi_1(x_m), \varphi_2(z)\}| \geq 2$.*

Proof. Suppose first that there exists $z \in X_2$ adjacent to x_{m+1} . Note that z is unique, $m \geq 2$ and $R(z) = x_{m-1}x_mx_{m+1}z$ is a 4-face. As G does not contain a 2-vertex with list of size three, $|L(x_m)| = 2$ and $|L(x_{m-1})| = |L(x_{m+1})| = 3$. This happens only in the cases (C2) and (C4) of the definition of X_1 , thus $x_1 \in X_1$ and $m \leq 3$. Furthermore, x_{m-1} is the only neighbor of z in X_1 and z is not adjacent to any other vertex of X_2 . As $R(z)$ is a 4-face and G does not contain 4-cycles adjacent to 4- or 5-cycles, z is not adjacent to p_3 and p_4 . By Lemma 14, z is not adjacent to p_1 and p_2 , either, thus any choice of the color for z is consistent with the precoloring of P . Let us distinguish the following cases:

- If $L(z) \cap L(x_m) \neq \emptyset$, then choose $c \in L(z) \cap L(x_m)$ and let $\varphi_1(x_m) = \varphi_2(z) = c$.
- If $L(z) \neq L(x_{m+1})$, then choose $\varphi_2(z) \in L(z) \setminus L(x_{m+1})$ and $\varphi_1(x_m) \in L(x_m)$ arbitrarily.

- Finally, consider the case that $L(z) \cap L(x_m) = \emptyset$ and $L(z) = L(x_{m+1})$, i.e., the lists of x_m and x_{m+1} are disjoint. We choose $\varphi_1(x_m) \in L(x_m)$ and $\varphi_2(z) \in L(z)$ arbitrarily.

On the other hand, suppose that no vertex of X_2 is adjacent to x_{m+1} . If $|L(x_{m+1})| = 2$, then choose $\varphi_1(x_m) \in L(x_m) \setminus L(x_{m+1})$. Otherwise, choose $\varphi_1(x_m) \in L(x_m)$ arbitrarily (in case that $m = 1$, choose a color different from the one in $L(p_4)$)

In both of these cases, the precoloring of x_m (and possibly z) can be extended to a proper coloring ψ of the subgraph induced by $\{x_1, \dots, x_m, z\}$ consistent with the precoloring of P . We fix φ_1 as the restriction of ψ to X_1 .

Let us now construct (the rest of) the coloring φ_2 . Consider a vertex $u \in X_2$ that is not adjacent to x_{m+1} . As $u \notin V(C)$, it holds that $|L(u)| = 3$. If u has no neighbor in X_2 , then it has two neighbors $r(u), x \in X_1$ and $R(u)$ is a 4-face. We claim that u has no neighbor $p_i \in V(P)$. Otherwise, we obtain $i \geq 3$ by Lemma 14. By Lemma 10, the 2-chord $p_i u r(u)$ splits off a 4- or 5-face. This face shares an edge with $R(u)$, which is a contradiction. Therefore, any choice of $\varphi_2(u) \in L(u) \setminus \{\varphi_1(x), \varphi_1(r(u))\}$ is consistent with the precoloring of P .

Finally, suppose that u has a neighbor $w \in X_2$. As we argued in the definition of X_2 , each of u and w has exactly one neighbor in X_1 , and u and w do not have any other neighbors in X_2 . Also, w is not adjacent to x_{m+1} , as otherwise G would contain a triangle or two adjacent 4-cycles. By Lemma 10(a), each of u and w has at most one neighbor in P . If one of them does not have any such neighbor, then we can easily color u and w , hence assume that $p_i u$ and $p_j w$ are edges. By Lemma 14, $i, j \geq 3$. Without loss on generality, $j = 3$ and $i = 4$. This is a contradiction, as the 4-face $p_3 p_4 u w$ shares an edge with $R(u)$. \square

Consider the colorings φ_1 and φ_2 constructed in Lemma 15. Let $G' = G - (X_1 \cup X_2)$ and let L' be the list assignment such that $L'(v)$ is obtained from $L(v)$ by removing the colors of the neighbors of v in X_1 and X_2 for $v \neq x_1$, and $L'(x_1) = L(x_1)$ if $x_1 \notin X_1$. Suppose that G' with the list assignment L' satisfies assumptions of Theorem 3. Then there exists an L' -coloring φ of G' , which together with φ_1 and φ_2 gives an L -coloring of G : this is obvious if $x_1 \in X_1$. If $x_1 \notin X_1$, then $|L(x_1)| = 2$, and $L(p_4) \subseteq L(x_1)$ by the minimality of G (otherwise, we could remove the edge $p_4 x_1$). By the choice of φ_1 , it holds that $\varphi_1(x_2) \neq \varphi(x_1)$. Since no other vertex of X

may be adjacent to x_1 by Lemmas 7 and 10, φ together with φ_1 and φ_2 is a proper coloring of G . As G is a counterexample to Theorem 3, it follows that L' violates assumptions of Theorem 3, i.e.,

- (a) a vertex $v \in V(G')$ with $|L'(v)| = 2$ is adjacent to two vertices of P ; or
- (b) $|L'(v)| \leq 1$ for some $v \in V(G') \setminus V(P)$; or
- (c) two vertices $u, v \in V(G')$ with $|L'(u)| = |L'(v)| = 2$ are adjacent.

Let us now consider each of these possibilities separately.

- (a) *A vertex $v \in V(G')$ with $|L'(v)| = 2$ is adjacent to two vertices of P .*
By Lemmas 7 and 10(a), this is not possible.

- (b) *$|L'(v)| \leq 1$ for some $v \in V(G') \setminus V(P)$.* If $|L(x_{m+1})| = 2$, then x_{m+1} does not have a neighbor in X_2 by Lemma 10 and hence $|L'(x_{m+1})| = 2$ by the choice of φ_1 . If $|L(x_{m+1})| = 3$, then the choice of φ_1 and φ_2 according to Lemma 15 ensures $|L'(x_{m+1})| \geq 2$. Therefore, $v \neq x_{m+1}$.

Since G has neither chords nor 2-chords starting in X_1 and ending in a vertex with list of size two, it holds that $|L(v)| = 3$. Therefore, v has at least two neighbors $u_1, u_2 \in X_1 \cup X_2$. If at least one of u_1 and u_2 belonged to X_1 , then v would be included in X_2 , hence we may assume that $u_1, u_2 \in X_2$.

Consider the path $x_i u_1 v u_2 x_j$, where $x_i = r(u_1)$ and $x_j = r(u_2)$. We may assume that $i \leq j$. The cycle $x_i \dots x_j u_2 v u_1$ has length at most six, thus it bounds a face F . Note that $i = j$, as each of $R(u_1)$ and $R(u_2)$ shares at least one edge with the path induced by X_1 and $F \neq R(u_1) \neq R(u_2) \neq F$. Therefore, F is a 4-face sharing an edge with 4-face $R(u_1)$ (and also with $R(u_2)$), which is a contradiction. Therefore, $|L'(v)| \geq 2$ for every $v \in V(G') \setminus V(P)$.

- (c) *Two vertices $u, v \in V(G')$ with $|L'(u)| = |L'(v)| = 2$ are adjacent.* As the vertices with lists of size two form an independent set in G , we may assume that $|L(u)| = 3$. Let y_1 be a neighbor of u in $X_1 \cup X_2$.

Consider first the case that $|L(v)| = 2$. If $u \notin V(C)$, then by Lemma 10, $y_1 \notin V(C)$, and thus $y_1 \in X_2$ and $u y_1 v$ is a 3-chord. By Lemma 13, this 3-chord splits off a 4-face F . Note that $F \neq R(y_1)$, as $u \notin X_2$. This is impossible, as the 4-face F would share an edge with $R(y_1)$. Therefore, $u \in V(C)$, and hence $v \neq x_1$. If $y_1 \in X_2$, then

$uy_1r(y_1)$ is a 2-chord, and by Lemma 10, it splits off a 4-face adjacent to $R(y_1)$, which is again a contradiction. Assume now that $y_1 \in X_1$. As C does not have chords, it follows that $y_1 = x_m$ and $u = x_{m+1}$. However, in that case $v = x_{m+2}$ and $|L(x_{m+2})| = 2$, which contradicts the choice of X_1 .

Consider now the case that $|L(v)| = 3$. Let y_2 be a neighbor of v in $X_1 \cup X_2$. As $u, v \notin X_2$, at least one of y_1 and y_2 , say y_1 , belongs to X_2 . Let us consider the possibilities $y_2 \in X_1$ and $y_2 \in X_2$ separately:

- $y_2 \in X_1$: The cycle formed by $r(y_1)y_1uvy_2$ and a part of the path $x_1x_2x_3x_4$ between $r(y_1)$ and y_2 has length at most six, thus it bounds a face F . Note that $R(y_1)$ shares an edge with F . Let k_1 and k_2 be the number of edges that $R(y_1)$ and F , respectively, share with the path induced by X_1 , $k_1 \geq \ell(R(y_1)) - 3 \geq 1$ and $k_2 = \ell(F) - 4 \geq 0$. Since $|X_1| \leq 3$, it holds that $k_1 + k_2 \leq 2$. If $k_1 = 1$, then $R(y_1)$ is a 4-face. Since 4- and 5-faces cannot be adjacent to $R(y_1)$, we obtain $\ell(F) \geq 6$. It follows that $k_2 \geq 2$, which is a contradiction. Similarly, if $k_1 = 2$, then F cannot be a 4-face, hence $\ell(F) \geq 5$ and thus $k_2 \geq 1$. This is again a contradiction.
- $y_2 \in X_2$: Let F be the cycle bounded by $r(y_1)y_1uvy_2r(y_2)$ and the part of the path $x_1x_2x_3x_4$ between $r(y_1)$ and $r(y_2)$. As $\ell(F) \leq 7$, F bounds a face. Note that $R(y_1) \neq R(y_2)$ and $\ell(R(y_1)) = \ell(R(y_2)) = 4$, as each of $R(y_1)$ and $R(y_2)$ shares an edge with the path induced by X_1 . Since F shares edges with both $R(y_1)$ and $R(y_2)$, $\ell(F) \geq 6$. It follows that F shares at least one edge with the path induced by X_1 as well. However, this is impossible, since $|X_1| \leq 3$.

Therefore, the assumptions of Theorem 3 are satisfied by G' and L' . We conclude that we can find a proper coloring of G , which contradicts the choice of G as a counterexample to Theorem 3. \square

References

- [1] P. Erdős, A. L. Rubin, H. Taylor, *Choosability in graphs*, Combinatorics, graph theory and computing, Proc. West Coast Conf., Arcata/Calif. 1979, 125–157, 1980.

- [2] H. Grötzsch, *Ein Dreifarbenatz für dreikreisfreie netze auf der kugel*, Math.-Natur. Reihe, 8:109–120, 1959.
- [3] J. Kratochvíl, Z. Tuza, *Algorithmic complexity of list colorings*, Discrete Appl. Math., 50(3):297–302, 1994.
- [4] P. C. B. Lam, W. C. Shiu, Z. M. Song, *The 3-choosability of plane graphs of girth 4*, Discrete Math., 294(3):297–301, 2005.
- [5] X. Li, *On 3-choosable planar graphs of girth at least 4*, to appear in Discrete Math.
- [6] B. Lidický, *On 3-choosability of plane graphs without 6-, 7- and 8-cycles*, submitted, preprint available as ITI-Series 2008-373.
- [7] C. Thomassen, *Every planar graph is 5-choosable*, J. Combin. Theory Ser. B, 62(1):180–181, 1994.
- [8] C. Thomassen, *3-list-coloring planar graphs of girth 5*, J. Combin. Theory Ser. B, 64(1):101–107, 1995.
- [9] V. G. Vizing, *Vertex colorings with given colors (in Russian)*, Metody Diskret. Analiz, Novosibirsk, 29:3–10, 1976.
- [10] M. Voigt, *List colourings of planar graphs*, Discrete Math., 120(1-3):215–219, 1993.
- [11] M. Voigt, *A not 3-choosable planar graph without 3-cycles*, Discrete Math., 146(1-3):325–328, 1995.
- [12] H. Zhang, *On 3-choosability of plane graphs without 5-, 8- and 9-cycles*, J. Lanzhou Univ., Nat. Sci., 41(3):93–97, 2005.
- [13] H. Zhang, B. Xu, *On 3-choosability of plane graphs without 6-, 7- and 9-cycles*, Appl. Math., Ser. B (Engl. Ed.), 19(1):109–115, 2004.
- [14] H. Zhang, B. Xu, Z. Sun, *Every plane graph with girth at least 4 without 8- and 9-circuits is 3-choosable*, Ars Comb., 80:247–257, 2006.
- [15] X. Zhu, M. Lianying, C. Wang, *On 3-choosability of plane graphs without 3-, 8- and 9-cycles*, Australas. J. Comb., 38:249–254, 2007.