

Identifying codes in (random) geometric networks*

Tobias Müller[†] Jean-Sébastien Sereni[‡]

Abstract

It is important for networks built from wireless sensors technology to have a functional location detection system. Identifying codes, first introduced to model fault diagnosis of multi-processor systems [10], have recently proved to be useful to address this question [17, 16]. We are interested in the situation where the area of communication of each sensor is modelled by a disk: thus we consider identifying codes for the class of unit disk graphs. Minimising the size of an identifying code is \mathcal{NP} -complete even for bipartite graphs [6]. First, we improve this result by showing that the problem remains \mathcal{NP} -complete for bipartite planar unit disk graphs. Then, we address the question of the existence of an identifying code for random unit disk graphs. From a practical point of view, this corresponds to the case when sensors are randomly thrown on a plane. We derive the probability that there exists an identifying code as a function of the radius of the disks. The results obtained are in sharp contrast with those concerning random graphs in the Erdős and Rényi model [8].

*This work was partially supported by the European project IST FET AEOLUS.

[†]European Institute for Stochastics (EURANDOM), Technical University Eindhoven, P.O. Box 513, 5600 MB Eindhoven, The Netherlands. E-mail: t.muller@tue.nl.

[‡]Institute for Theoretical Computer Science (ITI), Faculty of Mathematics and Physics, Charles University, Malostranské náměstí 25, 118 00 Prague, Czech Republic. This author is supported by the European project IST FET AEOLUS. E-mail: sereni@sophia.inria.fr.

1 Introduction

Identifying codes are used in several applications. They were first introduced for fault diagnosis of multi-processor systems [10], but they proved to be useful in other areas, in particular location detection in harsh environments [16, 17, 4, 18]. Our study is motivated by this last application. More precisely, wireless sensors technology makes it possible to install small devices in existing infrastructure that can form a network. An important issue for these networks to be efficient is a functional location detection system, i.e., the ability to determine the locations of other parties.

Many described systems are based on the concept of proximity-based detection, in which user location is provided by a nearest sensor (references include [19, 12, 9, 15]). As noted in [16], such systems are not designed for robustness. Toward this end, a novel framework using identifying codes is proposed in [16]. The zone to be covered is divided into a finite set of regions, each of which being represented by a single point within its boundary. Then, the points are mapped to the vertices of a graph, and an edge is added between two vertices if and only if the corresponding points in the physical systems are able to communicate. The problem is to determine the nodes on which to place and activate sensors, such that each node is within the communication range of a different set of sensors. In other words, we want each resolvable position to be covered by a unique set of sensors, which allows to identify it.

With this application in mind, an important issue is the fundamental case when the areas of communication of sensors are represented by disks of fixed radius. The obtained graph is then a *unit disk graph*: given a set V of points in the plane and a distance threshold $r > 0$, let $G(V, r)$ denote the following graph. The vertex set is V , and distinct vertices are joined by an edge whenever the Euclidean distance between them is less than r . Any graph isomorphic to such a graph is called a *unit disk graph*. A *realisation*, or an *embedding*, of a unit disk graph G is a set V of points in the plane along with a distance threshold r such that $G(V, r) \simeq G$. Before going any further, let us formally define, in the graph terminology, identifying codes.

Given a graph $G = (V, E)$, let $\overline{N}(v)$ denote the *closed neighbourhood* of the vertex v , that is the set $\{u \in V : uv \in E\} \cup \{v\}$. A subset C of V is called a *code*. For every vertex $v \in V$, the *shadow* of v on a code C is $\text{Sh}_C(v) := \overline{N}(v) \cap C$. A code C is *covering* if and only if $\text{Sh}_C(v) \neq \emptyset$ for every vertex $v \in V$. It is *separating* if and only if, for every pair of distinct vertices (u, v) , $\text{Sh}_C(u) \neq \text{Sh}_C(v)$. A code which

is covering and separating is called *identifying*.

It is not hard to see that a graph has an identifying code if and only if the closed neighbourhoods of any two vertices are distinct — if there are two vertices with the same closed neighbourhood, they clearly cannot be separated, and otherwise the whole set of vertices is an identifying code. Thus, determining whether a given graph admits an identifying code is easy. On the contrary, minimising the size of an identifying code in an arbitrary graph is \mathcal{NP} -complete, even when restricted to bipartite graphs [6] — for \mathcal{NP} -completeness results regarding directed graphs, consult [5].

In the next section, we strengthen this result by showing that minimising the size of an identifying code in an arbitrary unit disk graph is \mathcal{NP} -complete, even when restricted to bipartite planar unit disk graphs.

In the last section, we perform random analysis, by studying the existence of an identifying code in random unit disk graphs: consider a sequence of graphs $(G_n)_n$ obtained as follows. Points $X_1, X_2, \dots, X_n \in \mathbb{R}^2$ are picked at random, i.i.d. according to some probability distribution ν on \mathbb{R}^2 , and G_n is the graph whose vertex set is $\{X_1, X_2, \dots, X_n\}$, with an edge between two vertices if and only if the corresponding points lie at distance less than $r(n)$ in the plane, where we assume that $r(n)$ is a sequence of distances. In full generality, any choice of ν that has a bounded probability density function is allowed. However, we shall restrict ourselves to the uniform distribution on $[0, 1]^2$ for the sake of readability. Yet, the results can be extended to other distributions, if needed. The reader is welcomed to consult [14] about random geometric graphs. We shall prove that no identifying codes exist for random unit disk graphs, that is the probability that G_n has an identifying code tends to zero as n tends to infinity. Notice that this behaviour completely differs from what happens with the Erdős-Rényi model for random graphs: as shown in [8], if p and $1 - p$ both are at least $\frac{4 \log \log n}{\log n}$, then almost every graph in $\mathcal{G}_{n,p}$ admits an identifying code, and the minimum size of such a code is equivalent to $\frac{2 \log n}{\log(1/(p^2 + (1-p)^2))}$.

2 Complexity

Minimising the size of an identifying code is \mathcal{NP} -complete for arbitrary bipartite graphs [6]. We extend this result to arbitrary planar bipartite unit disk graphs.

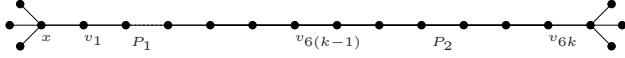

Figure 1: Decomposition of P into P_1 and P_2 in the proof of Lemma 2.

Theorem 1 *The following problem is \mathcal{NP} -complete:*

INSTANCE: *A planar bipartite unit disk graph G and a positive integer k .*

QUESTION: *Does G have an identifying code of size at most k ?*

As it will appear in the proof, the problem is \mathcal{NP} -complete even if an embedding of the unit disk graph is given. This is important since determining whether an arbitrary graph is a unit disk graph is \mathcal{NP} -complete [3].

So as to prove this theorem, we shall need two lemmas. Given a graph G , call an *handle* of G any induced path of G whose vertices all have degree two in G .

Lemma 2 *Consider any graph G with an handle $P := v_1v_2 \dots v_{6k}$ of order $6k$ for a positive integer k . Denote by x the neighbour of v_1 in $V(G) \setminus \{v_2\}$. Then, any identifying code C of G contains at least $3k$ vertices of P . Moreover, if C contains exactly $3k$ of these vertices and if $v_{6k} \in C$, then $x \in C$.*

Proof: The proof is by induction on the positive integer k , the result being easily checked if $k = 1$. So, suppose that the result is true for an integer $k - 1 \geq 1$, and let us prove it for k . Let P be an handle as in the statement of the lemma, and C an identifying code of G . The vertices $v_1, v_2, \dots, v_{6(k-1)}$ form an handle P_1 of G , and the vertices $v_{6(k-1)+1}, \dots, v_{6k}$ form an handle P_2 of order 6 (see Figure 1). By the induction hypothesis, C contains at least $3(k - 1)$ vertices of P_1 . As the result is true when k is one, C contains at least three vertices of P_2 . Therefore, C contains at least $3k$ vertices of P . Moreover, if C contains exactly $3k$ of these vertices, then it contains exactly $3(k - 1)$ vertices of P_1 and three vertices of P_2 . So, if in addition $v_{6k} \in C$, then $v_{6(k-1)} \in C$, since it is the neighbour of $v_{6(k-1)+1}$ not in P_2 . Now, using the induction hypothesis on P_1 , we deduce that $x \in C$, as desired. \square

The next lemma deals with the property of a particular graph, called a *variable-gadget*.

Definition 3 A *variable-gadget of order η* , see Figure 2 for an example, is the graph $K = (V, E)$ where

Suppose now that C contains a vertex of P and a vertex of N . Then, by the previous remark, observe that there must exist indices i, j, k such that $u_i \in C$, $v_j \in C$ and z_k is adjacent to both u_i and v_j . Still by the previous assertion, there also exist an index $k' \neq k$, together with indices i', j' such that $u_{i'} \in C$, $v_{j'} \in C$ and $z_{k'}$ is adjacent to both $u_{i'}$ and $v_{j'}$ (hence, at least one of i', j' is different from i and j). But then, the number of vertices of C in $N \cup P$ must be at least $\eta + 1$, which concludes the proof. \square

Proof of Theorem 1: Let us outline the proof before going into details. Consider an instance $I = (\varepsilon, X)$ of 3-SAT, where $\varepsilon = (C_1, C_2, \dots, C_m)$ is a set of clauses over the set of variables $X = \{x_1, x_2, \dots, x_n\}$. We can associate to I a bipartite graph H constructed by taking vertex set $\varepsilon \cup X$ and edges $x_i C_j \in E(H)$ if either $x_i \in C_j$ or $\bar{x}_i \in C_j$. PLANAR 3-SAT is the 3-SAT problem for the class of all instances for which H is planar. In [11], it is shown that PLANAR 3-SAT is \mathcal{NP} -complete. So, consider an instance I of PLANAR 3-SAT.

First we shall compute, in polynomial-time, a particular embedding of H , so-called *box-orthogonal embedding*. Then, we construct from it a planar bipartite unit disk graph G along with an embedding \hat{H} , still in polynomial-time, which has an identifying code of size at most $f(\hat{H})$ if and only if I can be satisfied. As the function f , to be made precise later, is polynomially computable, this will yield the desired result.

A *box-orthogonal embedding* of H is a planar embedding of H such that each edge is represented by alternate horizontal and vertical line segments, and each vertex is represented by a (possibly degenerate) rectangle, called a *box*. All line segments, including those at the perimeter of a box, are assumed to lie on lines of the integer grid — see Figure 2. Each planar graph has such an embedding, and it can be computed in polynomial-time [7, 13]. Observe that, by sufficiently subdividing the grid, we can ensure enough space between edges for what follows.

First, remark that every vertex of degree at most four can indeed be represented by just a point, and not a (non-degenerated) rectangle: it suffices for this to arrange edges incident to this vertex, see Figure 5(a). Thus, we suppose now that all the vertices of ε are represented by points.

We ensure that every vertex $x_i \in X$ is represented by a rectangle, sufficiently big so that a variable-gadget K_i of order m can be embedded on its perimeter, as shown in Figure 4.

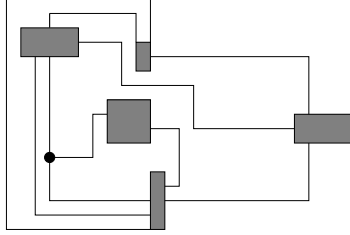

Figure 3: Example of a box-orthogonal embedding.

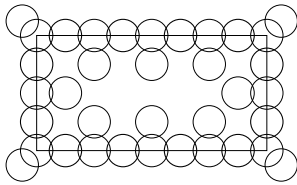

Figure 4: Embedding of a variable-gadget around a box. The bold circles represent the vertices of $P \cup N$.

The edges around a box B_i are modified as shown in Figure 5(b), so as to ensure that an edge coming from a vertex \mathcal{C}_j reaches a vertex of P_i if $x_i \in \mathcal{C}_j$, and a vertex of N_i if $\bar{x}_i \in \mathcal{C}_j$. Note that, for each variable gadget K_i , only the vertices of $P_i \cup N_i$ can have neighbours outside of K_i , and each of them can have at most one such neighbour.

Now, we compute the length of each edge, and we subdivide each edge by points with rational coordinates so that

- each edge contains a number of points which is a multiple of 6; and
- every two non-consecutive points on an edge are at distance at least $1 + 2\nu$ for some fixed positive rational ν .

All these points are added to the vertex set of the graph G we are building. Notice that this step also can be done in polynomial-time.

Last, we add a neighbour \mathcal{O}_j to each vertex $\mathcal{C}_j \in \varepsilon$ (this does not prevent the graph from being a unit disk graph since the vertices of ε had degree three). The obtained graph G is a planar unit disk graph, a realisation \hat{H} being obtained from the planar embedding we built by centring a disk of radius $1/2 + \nu$ at each vertex. It is moreover bipartite: the following 2-colouring of G is clearly proper.

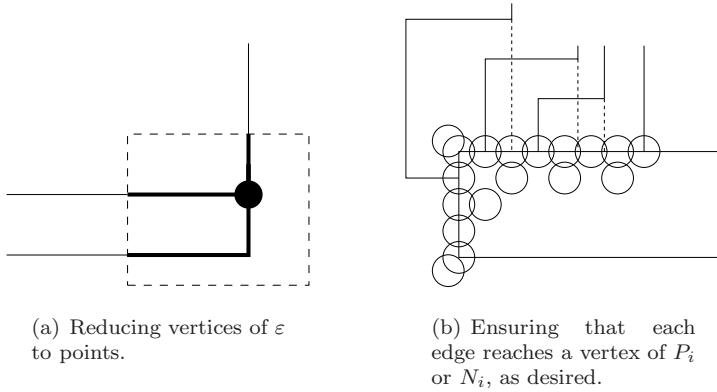

Figure 5: Modifications of the embedding of the edges of H .

Colour 1 the vertices of ε . In each variable-gadget, colour 1 the vertices of $P \cup N \cup \{y_1, y_2, \dots, y_{2\eta}\}$ and 2 the remaining vertices, i.e., $z_1, z_2, \dots, z_{2\eta}$. Last, for each path P , alternatively colour 1 and 2 its vertices such that the endvertex adjacent to a vertex of a variable-gadget is coloured 1, and the other endvertex 2 — this is possible since each such path has even order.

We prove now that I can be satisfied if and only if G has a code of size at most $f(\mathring{H})$, defined below. For each clause \mathcal{C}_j three paths, denoted by p_j^i for $i \in \{1, 2, 3\}$, join the vertex \mathcal{C}_j to the corresponding literals. Let γ_j^i be the number of internal vertices of the path p_j^i — note that each γ_j^i is of the form $6s$ for some positive integer $s = s(i, j)$. Set

$$f(\mathring{H}) := 2nm + m + \frac{1}{2} \sum_{j=1}^m \gamma_j^1 + \gamma_j^2 + \gamma_j^3.$$

Suppose first that I can be satisfied, and let us construct an identifying code C of size at most $f(\mathring{H})$. For each variable x_i , the vertices of P_i are added to C if x_i is true, and the vertices of N_i are added to C otherwise. We also add the vertices z_j of R_i . So far we have $n \times 2m$ vertices in C . Consider a path p_j^i : its vertices are denoted by $xv_1v_2 \dots v_{6k}\mathcal{C}_j$, so x belongs to a variable-gadget. If the literal to which x corresponds is true, then x is in C : we add to C the vertices v_{2i} for $i \in \{1, 2, \dots, 3k\}$. Otherwise, we add to C the vertices v_{2i-1} for $i \in \{1, 2, \dots, 3k\}$. Last, we add to C the vertices o_j for

$j \in \{1, 2, \dots, m\}$. The obtained code C has size $f(\hat{H})$. Notice that every vertex \mathcal{C}_j has at least one neighbour in C different from o_j , since the clause \mathcal{C}_j is satisfied. The code C is an identifying code: all the vertices are covered. For every $j \in \{1, 2, \dots, m\}$, $\text{Sh}_C(o_j) = \{o_j\}$, and the shadow of \mathcal{C}_j on C consists of $\{o_j\}$ and at least one other vertex. The other vertices are clearly separated.

Conversely, suppose that G has an identifying code C of size at most $f(\hat{H})$. By Lemmas 2 and 4, C contains at least $\gamma_j^i/2$ internal vertices of p_j^i , and at least $2m$ vertices in each variable-gadget. Moreover, C must contain at least one vertex among \mathcal{C}_j, o_j so as to cover o_j . Hence, the code C contains exactly that number of vertices in each of the subgraphs mentioned. Also, by Lemma 4, for each variable-gadget K_i , either $N_i \subset C$ and $P_i \cap C = \emptyset$, or $P_i \subset C$ and $N_i \cap C = \emptyset$. In the former case, set the corresponding variable x_i to false, and set it to true in the latter case. Consider now any clause \mathcal{C}_j : we infer that at least one neighbour of \mathcal{C}_j different from o_j also belongs to C (otherwise C would not be separating \mathcal{C}_j and o_j). Consider the path p_j^i to which this vertex belongs: its internal vertices form an handle $v_1 v_2 \dots v_{6k}$ of G . The code C contains exactly $\gamma_j^i/2$ vertices of this handle, and $v_{6k} \in C$. Therefore, the neighbour of v_1 different from v_2 also belongs to C , by Lemma 2. By the definition, this vertex belongs to $P_i \cup N_i$ for some variable-gadget K_i , and hence the corresponding literal is true. Thus, the clause \mathcal{C}_j is satisfied. \square

3 Random unit disk graphs

3.1 Statement of results

In this section, we consider the random unit disk graph G_n described in the Introduction. Furthermore, to simplify the computations we will make the *toroidal convention*, i.e., we identify opposite edges on $[0, 1]^2$ (making it into a torus). We shall prove the following theorem.

Theorem 5 *The following hold for G_n under the assumptions stated:*

$$\lim_{n \rightarrow \infty} \mathbb{P}(G_n \text{ has an ID-code}) = \begin{cases} 1 & \text{if } nr^2 \ll n^{-1}, \\ \exp[-\frac{\pi\lambda}{2}] & \text{if } nr^2 \sim \lambda n^{-1}, \\ & \text{for some } \lambda > 0, \\ 0 & \text{if } n^{-1} \ll nr^2 \ll 1, \\ \exp[-\mu(r)] & \text{if } 0 < r < \frac{1}{2}\sqrt{2} \\ & \text{is fixed;} \\ 0 & \text{if } r \geq \frac{1}{2}\sqrt{2}. \end{cases}$$

where for $0 < r \leq \frac{1}{2}$, we set

$$\mu(r) := \frac{\pi}{16r^2},$$

and for $\frac{1}{2} < r < \frac{1}{2}\sqrt{2}$, we set

$$\begin{aligned} \mu(r) := & \frac{1}{4r^2 \sin\left(\frac{\beta}{2}\right)^2} \left[\frac{\cos\left(\frac{\beta}{2}\right)}{\cos\left(\frac{\beta}{2}\right) + \sin\left(\frac{\beta}{2}\right)} - \frac{1}{2} \right] \\ & + \frac{1}{4r^2 \sin(\beta)} \left[\frac{2 \left(\cos\left(\frac{\beta}{2}\right) - \sin\left(\frac{\beta}{2}\right)\right) \tan\left(\frac{\beta}{4}\right)}{\left(1 - \cos\left(\frac{\beta}{2}\right) + \sin\left(\frac{\beta}{2}\right)\right) \tan\left(\frac{\beta}{4}\right)^2 + 1 + \cos\left(\frac{\beta}{2}\right) - \sin\left(\frac{\beta}{2}\right)} \right. \\ & \left. + \frac{2}{\sqrt{\sin(\beta)}} \arctan \left(\sqrt{\frac{\left(1 - \cos\left(\frac{\beta}{2}\right) + \sin\left(\frac{\beta}{2}\right)\right) \tan\left(\frac{\beta}{4}\right)}{\left(1 + \cos\left(\frac{\beta}{2}\right) - \sin\left(\frac{\beta}{2}\right)\right)}} \tan\left(\frac{\beta}{4}\right) \right) \right], \end{aligned}$$

with $\beta = \beta(r) := \frac{\pi}{2} - 2 \arccos\left(\frac{1}{2r}\right)$.

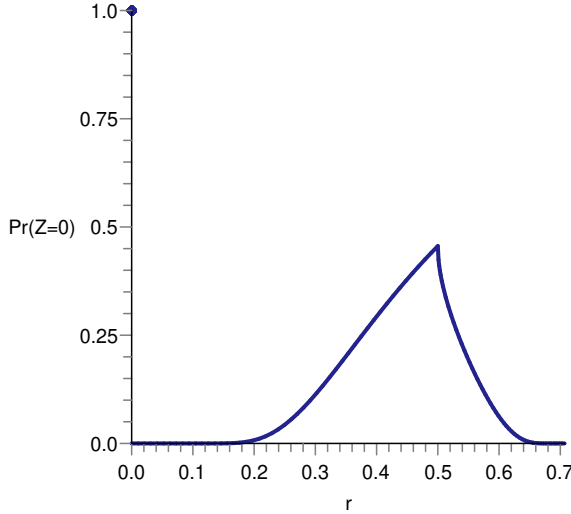

Figure 6: The (asymptotic) probability that an identifying code exists as a function of r , for r fixed.

The expression for $\mu(r)$ when $r > \frac{1}{2}$ given in Theorem 5 can be rewritten in terms of r using the relations

$$\begin{aligned}\cos\left(\frac{\beta}{2}\right) &= \frac{1}{2}\sqrt{2}\left(\frac{1}{2r} + \sqrt{1 - \frac{1}{4r^2}}\right), \\ \sin\left(\frac{\beta}{2}\right) &= \frac{1}{2}\sqrt{2}\left(\frac{1}{2r} - \sqrt{1 - \frac{1}{4r^2}}\right),\end{aligned}\tag{1}$$

together with $\tan\left(\frac{\beta}{4}\right) = \sqrt{\frac{1 - \cos\left(\frac{\beta}{2}\right)}{1 + \cos\left(\frac{\beta}{2}\right)}}$. Unfortunately, it does not appear possible to obtain a substantially simpler expression.

Notice that the toroidal convention does not affect the conclusion of Theorem 5 in the cases when $r \rightarrow 0$, and that for $r \leq \frac{1}{4}$ the probability that G_n has an identifying code without the toroidal assumption is no more than the probability with the toroidal assumption (so that for the case of fixed r the theorem provides an upper bound).

3.2 Proofs

Let us say that vertices X_i, X_j ($j \neq i$) of G_n form a *bad pair* if $C(X_i)\Delta C(X_j) = \emptyset$, where Δ denotes the symmetric difference and C denotes the closed neighbourhood (i.e., $C(v) = N(v) \cup \{v\}$). Let Z denote the number of bad pairs in G_n . Thus

$$\mathbb{P}(G_n \text{ has an ID-code}) = \mathbb{P}(Z = 0).\tag{2}$$

The very first assertion of Theorem 5 is rather trivial.

Lemma 6 *If $nr^2 \ll n^{-1}$ then $\mathbb{P}(Z = 0) = 1 + o(1)$.*

Proof: Notice that if G_n contains no edges at all then the whole set of vertices is an identifying code. Let $Y := |E(G_n)|$ be the number of edges of G_n . We see that

$$\mathbb{E}Y \leq \binom{n}{2}\pi r^2 = o(1).$$

So $|E(G_n)| = 0$ with probability $1 + o(1)$ and we are done. \square

Our next aim is to prove the theorem for r in the range $nr^2 \sim \frac{\lambda}{n}$. For this purpose we will use the following theorem by Penrose [14]. Originally it was phrased for arbitrary dimension d and any absolutely continuous probability distribution, but we have taken $d = 2$ and the uniform distribution on $[0, 1]^2$ here.

Theorem 7 (Penrose) *Let $k \in \mathbb{N}$ and suppose $(nr^2)^k \sim \lambda n^{-1}$ for some $\lambda > 0$. Then*

$$\begin{aligned} \lim_{n \rightarrow \infty} \mathbb{P}(\Delta(G_n) = k - 1) &= 1 - \lim_{n \rightarrow \infty} \mathbb{P}(\Delta(G_n) = k) \\ &= \exp \left[-\frac{\lambda}{(k+1)!} \int_{(\mathbb{R}^2)^k} h_k(\{0, x_1, \dots, x_k\}) dx_1 \dots dx_k \right], \end{aligned}$$

where $h_k(A)$ equals one if $\Delta(G(A, r)) \geq k$ and zero otherwise.

This result allows us to give a short proof of the following statement,

Lemma 8 *If $nr^2 \sim \frac{\lambda}{n}$ then $\mathbb{P}(Z = 0) \rightarrow e^{-\frac{\pi\lambda}{2}}$.*

Proof: We first claim that whp. there are no components of order at least three. To see this, let W be the collection of all 3-tuples $(X_{i_1}, X_{i_2}, X_{i_3}) \in \{X_1, \dots, X_n\}^3$ with i_1, i_2, i_3 distinct and $\|X_{i_1} - X_{i_2}\|, \|X_{i_1} - X_{i_3}\| < r$. Then

$$\mathbb{E}W = n(n-1)(n-2)(\pi r^2)^2 = O(n^{-1}).$$

So whp. G_n consists of components of size at most two (i.e., isolated vertices and isolated edges) and it follows that

$$\mathbb{P}(Z = 0) = \mathbb{P}(\Delta(G_n) = 0) + o(1).$$

Now applying Theorem 7 with $k = 1$ yields the result, since $\int_{\mathbb{R}^2} h_1(\{0, x\}) dx = \pi$. □

For convenience, we will split the case when $nr^2 \gg n^{-1}$ and $r = o(1)$ into two subcases (that require/allow different proof techniques).

Lemma 9 *If $n^{-1} \ll nr^2 \ll \ln n$ then $\mathbb{P}(Z = 0) = o(1)$.*

Proof: Denote by Y the number of isolated edges. For convenience, let us write $V_r(a_1, \dots, a_l) := \text{vol}(\cup_{i=1}^l B(a_i, r))$ for $a_1, \dots, a_l \in \mathbb{R}^2$ and $l \geq 1$. Then

$$\mathbb{E}Y = \binom{n}{2} \int_{[0,1]^2} \int_{B(x,r)} (1 - V_r(x, y))^{n-2} dy dx. \quad (3)$$

Notice that $\pi r^2 \leq V_r(x, y) \leq 2\pi r^2$. Because $\ln(1-x) = -x + O(x^2)$ and $r = o(1)$ we see that

$$\binom{n}{2} \pi r^2 e^{-(2\pi+o(1))nr^2} \leq \mathbb{E}Y \leq \binom{n}{2} \pi r^2 e^{-(\pi+o(1))nr^2}. \quad (4)$$

So we can write $\mathbb{E}Y \geq (n-1)nr^2 e^{-3\pi nr^2}$ (for n sufficiently large). The function $x e^{-3\pi x}$ is increasing for $x \leq (3\pi)^{-1}$ and decreasing

for $x \geq (3\pi)^{-1}$. Thus, for $(3\pi)^{-1} \leq nr^2 \ll \ln n$, we have $\mathbb{E}Y \geq (n-1)(3\pi)^{-1}e^{o(\ln n)} = n^{1+o(1)}$. For $n^{-1} \ll nr^2 \leq (3\pi)^{-1}$, we have $\mathbb{E}Y \geq (n-1)\frac{a(n)}{n}e^{o(1)} \sim a(n)$ where $a(n) \gg 1$ is such that $nr^2 \gg \frac{a(n)}{n}$. In particular, $\mathbb{E}Y \rightarrow \infty$. We now claim that

$$\text{Var}(Y) = o((\mathbb{E}Y)^2). \quad (5)$$

From this the statement will follow, because Chebyshev's inequality then gives:

$$\mathbb{P}(Z = 0) \leq \mathbb{P}(Y = 0) \leq \mathbb{P}(|Y - \mathbb{E}Y| \geq \mathbb{E}Y) \leq \frac{\text{Var}(Y)}{(\mathbb{E}Y)^2} = o(1).$$

Thus it only remains to prove (5). Notice that

$$\begin{aligned} (\mathbb{E}Y)^2 &= \left(\binom{n}{2} \int_{[0,1]^2} \int_{B(x,r)} (1 - V_r(x,y))^{n-2} dy dx \right)^2 \\ &= \binom{n}{2}^2 \int \int \int \int_A (1 - V_r(x_1, y_1))^{n-2} (1 - V_r(x_2, y_2))^{n-2} dy_2 dx_2 dy_1 dx_1, \end{aligned}$$

where A is the set of all $(x_1, y_1, x_2, y_2) \in ([0, 1]^2)^4$ with $y_1 \in B(x_1, r)$, $y_2 \in B(x_2, r)$. Let us set $\mathcal{P} := \binom{[n]}{2}$ and for $P = \{i, j\} \in \mathcal{P}$ denote by $I(P)$ the indicator variable of the event that $\{X_i, X_j\}$ spans an isolated edge. We have

$$\begin{aligned} Y^2 &= \sum_{\substack{P_1, P_2 \in \mathcal{P}, \\ |P_1 \cap P_2| = 2}} I(P_1)I(P_2) + \sum_{\substack{P_1, P_2 \in \mathcal{P}, \\ |P_1 \cap P_2| = 1}} I(P_1)I(P_2) + \sum_{\substack{P_1, P_2 \in \mathcal{P}, \\ |P_1 \cap P_2| = 0}} I(P_1)I(P_2) \\ &= \sum_{P \in \mathcal{P}} I(P) + \sum_{\substack{P_1, P_2 \in \mathcal{P}, \\ |P_1 \cap P_2| = 0}} I(P_1)I(P_2). \end{aligned}$$

Here we have used that $I \in \{0, 1\}$ and two isolated edges cannot meet in a single vertex. Thus,

$$\mathbb{E}Y^2 = \mathbb{E}Y + \binom{n}{2} \binom{n-2}{2} \iiint \int_{A_0} (1 - V_r(x_1, y_1, x_2, y_2))^{n-4} dy_2 dx_2 dy_1 dx_1, \quad (6)$$

where A_0 is the set of all $(x_1, y_1, x_2, y_2) \in A$ with $x_2, y_2 \notin B(x_1, r) \cup B(y_1, r)$. Let A_1 be the set of all $(x_1, y_1, x_2, y_2) \in A_0$ with $\|x_1 - x_2\| \geq 4r$ and set $A_2 := A_0 \setminus A_1$. Observe that for $(x_1, y_1, x_2, y_2) \in A_1$ holds $V_r(x_1, y_1, x_2, y_2) = V_r(x_1, y_1) + V_r(x_2, y_2)$. Hence,

$$(1 - 2\pi r^2)^{-4} (1 - V_r(x_1, y_1))^{n-2} (1 - V_r(x_2, y_2))^{n-2} \leq (1 - V_r(x_1, y_1, x_2, y_2))^{n-4} \leq$$

This shows that

$$\begin{aligned} & \binom{n}{2} \binom{n-2}{2} \iiint\!\!\!\int_{A_1} (1 - V_r(x_1, y_1, x_2, y_2))^{n-4} dy_2 dx_2 dy_1 dx_1 \\ & \leq (1 - \pi r^2)^{-4} \binom{n}{2}^2 \\ & \iiint\!\!\!\int_A ((1 - V_r(x_1, y_1))(1 - V_r(x_2, y_2)))^{n-2} dy_2 dx_2 dy_1 dx_1 \\ & = \\ & (1 + o(1))(\mathbb{E}Y)^2. \end{aligned}$$

And we see that

$$\begin{aligned} & \text{Var}(Y) = \mathbb{E}Y^2 - (\mathbb{E}Y)^2 \\ & \leq \mathbb{E}Y + (1 + o(1))(\mathbb{E}Y)^2 \\ & + \binom{n}{2} \binom{n-2}{2} \iiint\!\!\!\int_{A_2} (1 - V_r(x_1, y_1, x_2, y_2))^{n-4} dy_2 dx_2 dy_1 dx_1 - (\mathbb{E}Y)^2 \\ & = o((\mathbb{E}Y)^2) + O(n^4 r^6 e^{-\pi n r^2}). \end{aligned}$$

Here we have used that $\mathbb{E}Y = o((\mathbb{E}Y)^2)$ because $\mathbb{E}Y \rightarrow \infty$ in the last line. By a remark following (4) we get $n^4 r^6 e^{-\pi n r^2} / (\mathbb{E}Y)^2 = O(r^2 e^{5\pi n r^2})$. Recall that $n r^2 \ll \ln n$ and note that $x e^{5\pi x}$ is increasing, so that we can write $r^2 e^{5\pi n r^2} = \frac{1}{n} \cdot (n r^2) e^{5\pi(n r^2)} \leq n^{-1+o(1)}$. So (5) follows and we are done. \square

Lemma 10 *If $n r^2 \rightarrow \infty$ yet $r = o(1)$ then $\mathbb{P}(Z = 0) = o(1)$.*

The lemma will follow from the the following two lemmas together with the inequality $\mathbb{P}(Z = 0) \leq \frac{\text{Var}(Z)}{(\mathbb{E}Z)^2}$.

Lemma 11 *If $n r^2 \rightarrow \infty$ and $r < \frac{1}{2}\sqrt{2} - \epsilon$ for some $\epsilon > 0$ then*

$$\mathbb{E}Z = (1 + o(1))\mu(r).$$

Lemma 12 *If $n r^2 \rightarrow \infty$ and $r = o(1)$ then $\text{Var}(Z) = o(r^{-4})$.*

Before we can give the proof of these last two lemmas, we need to do some more ground work. Denote by $D_r(x, y)$ the area of the symmetric difference $B(x, r) \Delta B(y, r)$. This difference only depends on $\|y - x\|$ and the angle between $y - x$ and the line $\{(a, a) : a \in \mathbb{R}\}$. By a slight abuse of notation, we will also write $D_r(u, \alpha)$ for $D_r(x, y)$ if $u = \|y - x\|$ and α is the angle between $y - x$ and the line $\{(a, a) : a \in \mathbb{R}\}$. The computations below will make use of the following lemma.

Lemma 13 *If $0 < r < \frac{1}{2}$ then*

$$D_r(u, \alpha) = 4ur + O(u^2).$$

If $\frac{1}{2} \leq r < \frac{1}{2}\sqrt{2}$ then

$$D_r(u, \alpha) = \begin{cases} 4ur \sin\left(\frac{\beta}{2}\right) (\cos(\alpha) - \sin(\alpha)) + o(u) & \text{if } -\frac{\pi}{4} \leq \alpha < -\frac{\beta}{2}, \\ 4ur \left(1 - \left(\cos\left(\frac{\beta}{2}\right) - \sin\left(\frac{\beta}{2}\right)\right) \cos(\alpha)\right) + o(u) & \text{if } -\frac{\beta}{2} \leq \alpha \leq 0. \end{cases}$$

Here $\beta = \beta(r) = \frac{\pi}{2} - 2 \arccos\left(\frac{1}{2r}\right)$ as before. Furthermore, the error terms $O(u^2)$ and $o(u)$, respectively, can be bounded uniformly in α .

Proof: We need to consider the area $D_r(u, \alpha) = \text{vol}(B(x, r)\Delta B(y, r))$ for x, y with $\|x - y\| = u$ and the angle between $y - x$ and the diagonal $\{(a, a)^T : a \in \mathbb{R}\}$ is α . For ease of computation, let us work with $[-\frac{1}{2}, \frac{1}{2}]^2$ instead of $[0, 1]^2$ in this proof, and notice that by symmetry we may assume $x = (0, 0)^T$ is the center of the unit square. Let $v_\alpha := (\cos(\frac{\pi}{4} + \alpha), \sin(\frac{\pi}{4} + \alpha))^T$ be a unit vector that makes an angle α with the diagonal of the unit square. Let $w_\alpha := (\cos(\frac{3\pi}{4} + \alpha), \sin(\frac{3\pi}{4} + \alpha))^T$ be a unit vector that is perpendicular to v_α . First, consider $0 < r < \frac{1}{2}$. In this case, for u small enough, $B(x, r)\Delta B(y, r)$ lies completely in the interior of the unit square (so there are no effects due to the toroidal assumption). Denote the boundary of $B(x, r)$ by S , and set $H_\alpha(c) := \{p : p \cdot w_\alpha = c\}$. Hence, $H_\alpha(c)$ is a line parallel to v_α . We will approximate $D_r(u, \alpha)$ by $\text{vol}(S + [0, u]v_\alpha) \leq 4ur$. Remark that the height of S is $2r$. Also, observe that for most $c \in (-r, r)$, the set $(B(x, r)\Delta B(y, r)) \cap H_\alpha(c)$ and the set $(S + [0, u]v_\alpha) \cap H_\alpha(c)$ both consist of two line segments, each of length u . It is not hard to see that the c for which this is not the case are contained in $(-r, -r + u) \cup (r - u, r)$, so that

$$4ur \geq D_r(u, \alpha) \geq 4ur - 2u^2.$$

This concludes the proof for the case $0 < r < \frac{1}{2}$.

Let us now consider $\frac{1}{2} \leq r < \frac{1}{2}\sqrt{2}$. We will proceed in a similar manner. Let S again denote the boundary of $B(x, r)$. But note that now, due to the toroidal assumption, S consists of four arcs of opening angle β (see figure 7). We again wish to approximate $D_r(u, \alpha)$ by the area of $S + [0, u]v_\alpha$. Let $h(\alpha)$ be the length ‘‘counting multiplicities’’ of the projection of S onto $\mathcal{L}(w_\alpha)$, i.e., $h(\alpha) = \int_{\mathbb{R}} |H_\alpha(c) \cap S| dc$. We claim that

$$D_r(u, \alpha) = uh(\alpha) + o(u).$$

To see this, note that the length of $(B(x, r)\Delta B(y, r)) \cap H_\alpha(c)$ equals u times the cardinality of $S \cap H_\alpha(c)$, unless one or more of the points in $S \cap H_\alpha(c)$ are

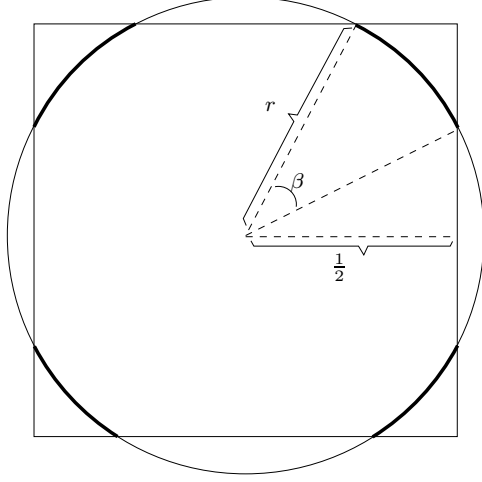

Figure 7: The “boundary” of $B(x, r)$ consists of four arcs of opening angle β .

- a) within u of the boundary of the square, or
- b) within u of another point of $S \cap H_\alpha$.

We have already seen that the error due to b) can be bounded by $2u^2$. In order to bound the error due to a), let $S'(u)$ be the set of all $s \in S$ for which a) is not the case. Clearly, as u tends to 0 the length $l(S'(u))$ of $S'(u)$ tends to the length $l(S)$ of S . We see that

$$uh(\alpha) - u(l(S) - l(S'(u))) - 2u^2 \leq D_r(u, \alpha) \leq uh(\alpha),$$

as required. Since $l(S) - l(S'(u))$ does not depend on α the error term is indeed uniform in α .

It only remains to compute $h(\alpha)$: for $\frac{\pi}{4} < \alpha \leq -\frac{\beta}{2}$, the length of the projections on $\mathcal{L}(w_\alpha)$ of the two arcs that contain the diagonal of the square is r times $(\sin(\frac{\beta}{2} - \alpha) - \sin(-\frac{\beta}{2} - \alpha))$, and the height of the other two arcs is r times $(\sin(\frac{\pi}{2} - \frac{\beta}{2} - \alpha) - \sin(\frac{\pi}{2} + \frac{\beta}{2} - \alpha))$. Thus, for $\frac{\pi}{4} < \alpha < -\frac{\beta}{2}$ we get

$$\begin{aligned} h(\alpha) &= \\ &= 2r (\sin(\frac{\beta}{2} - \alpha) - \sin(-\frac{\beta}{2} - \alpha) + \sin(\frac{\pi - \beta}{2} - \alpha) - \sin(\frac{\pi + \beta}{2} - \alpha)) \\ &= 2r (\sin(\frac{\beta}{2} - \alpha) - \sin(-\frac{\beta}{2} - \alpha) + \cos(-\frac{\beta}{2} - \alpha) - \cos(\frac{\beta}{2} - \alpha)) \\ &= 4r \sin(\frac{\beta}{2}) (\cos(\alpha) - \sin(\alpha)) \end{aligned}$$

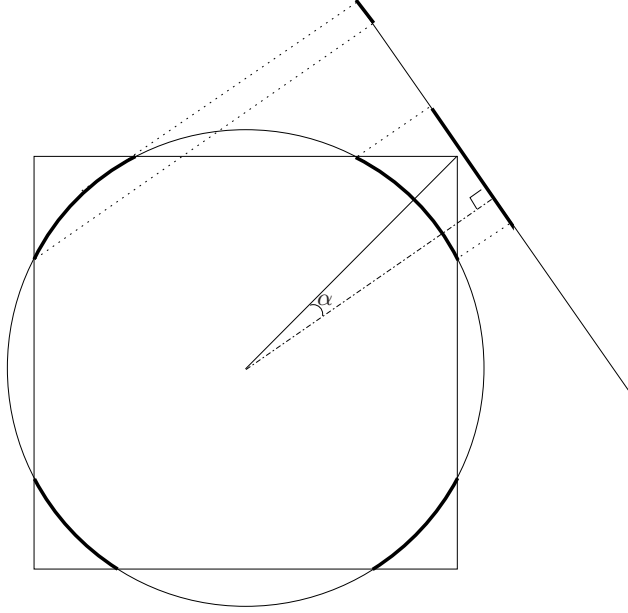

Figure 8: The projections of the four arcs onto $\mathcal{L}(w_\alpha)$.

For $-\frac{\beta}{2} < \alpha < \frac{\beta}{2}$, we obtain

$$\begin{aligned}
 h(\alpha) &= \\
 &= 2r \left(\sin\left(\frac{\beta}{2} - \alpha\right) - \sin\left(-\frac{\beta}{2} - \alpha\right) + 2 - \sin\left(\frac{\pi - \beta}{2} - \alpha\right) - \sin\left(\frac{\pi + \beta}{2} - \alpha\right) \right) \\
 &= 2r \left(\sin\left(\frac{\beta}{2} - \alpha\right) - \sin\left(-\frac{\beta}{2} - \alpha\right) + 2 - \cos\left(-\frac{\beta}{2} - \alpha\right) - \cos\left(\frac{\beta}{2} - \alpha\right) \right) \\
 &= 4r \left(1 - \left(\cos\left(\frac{\beta}{2}\right) - \sin\left(\frac{\beta}{2}\right) \right) \cos(\alpha) \right).
 \end{aligned}$$

This concludes the proof. \square

It should be remarked that, for $r \in (0, \frac{1}{2})$, the result can also be obtained in a relatively straightforward manner by explicitly computing $D_r(u, \alpha) = 2\pi r^2 - 4r^2 \arccos\left(\frac{u}{2r}\right) + 2u\sqrt{r^2 - \frac{u^2}{4}}$ and considering the Taylor expansion of this expression. We have not chosen this route here because the method used fits better with the $\frac{1}{2} \leq r < \frac{1}{2}\sqrt{2}$ case.

Proof of Lemma 11: Notice that by symmetry, switching to polar

coordinates

$$\begin{aligned}
\mathbb{E}Z &= \binom{n}{2} \int_{[0,1]^2} \int_{B(x,r)} (1 - D_r(x,y))^{n-2} dy dx \\
&= \binom{n}{2} \int_0^{2\pi} \int_0^r (1 - D_r(u,\alpha))^{n-2} u du d\alpha \\
&= \binom{n}{2} 8 \int_{-\frac{\pi}{4}}^0 \int_0^r (1 - D_r(u,\alpha))^{n-2} u du d\alpha.
\end{aligned}$$

Let us write

$$F_r(\alpha) := \begin{cases} 1 & \text{if } r \leq \frac{1}{2}, \\ \sin\left(\frac{\beta}{2}\right) (\cos(\alpha) - \sin(\alpha)) & \text{if } r > \frac{1}{2} \text{ and } \\ 1 - (\cos\left(\frac{\beta}{2}\right) - \sin\left(\frac{\beta}{2}\right)) \cos(\alpha) & \text{if } r > \frac{1}{2} \text{ and } \end{cases}$$

$$\begin{cases} -\frac{\pi}{4} < \alpha < -\frac{\beta}{2}, \\ -\frac{\beta}{2} \leq \alpha \leq 0. \end{cases}$$

Therefore, by Lemma 13 we have $D_r(u,\alpha) = 4urF_r(\alpha) + o(u)$. Now, observe that $F_r(\alpha) > c$ for some $c = c(\epsilon)$ uniformly in all r considered (recall that $r < \frac{1}{2}\sqrt{2} - \epsilon$). By Lemma 13, for every $\epsilon > 0$ there exists a $\delta > 0$ such that, if $u < \delta r$, then $(4 - \epsilon)urF(\alpha) < D_r(u,\alpha) < (4 + \epsilon)urF_r(\alpha)$. Now notice that for $u > \delta r$ we have $D_r(u,\alpha) = \Omega(r^2)$.

$$\begin{aligned}
&\int_0^{2\pi} \int_0^r (1 - D_r(u,\alpha))^{n-2} u du d\alpha = \\
&\int_0^{2\pi} \int_0^{\delta r} (1 - D_r(u,\alpha))^{n-2} u du d\alpha + \int_0^{2\pi} \int_{\delta r}^r (1 - D_r(u,\alpha))^{n-2} u du d\alpha \\
&\leq \int_0^{2\pi} \int_0^{\delta r} (1 - D_r(u,\alpha))^{n-2} u du d\alpha + \pi r^2 e^{-\Omega(nr^2)}.
\end{aligned} \tag{7}$$

We shall see later on that the last term on the last line is negligibly small compared to the first term on the last line, but first we must compute the first term in the last line. We have

$$\begin{aligned}
&\int_0^{2\pi} \int_0^{\delta r} (1 - D_r(u,\alpha))^{n-2} 2\pi u du d\alpha \leq \\
&\int_0^{\delta r} \exp[-(n-2)(4-\epsilon)urF(\alpha)] 2\pi u du d\alpha \\
&= \int_0^{2\pi} \frac{1}{((4-\epsilon)(n-2)rF(\alpha))^2} \int_0^{\delta(4-\epsilon)r^2(n-2)} e^{-v} v dv d\alpha \\
&\leq \frac{1+o(1)}{(4-\epsilon)^2 n^2 r^2} \int_0^{2\pi} \frac{1}{F(\alpha)^2} d\alpha,
\end{aligned}$$

where we have used the substitution $v = (n-2)(4-\epsilon)urF(\alpha)$ in the first equality and for the second equality we have used that nr^2 tends to infinity together with the fact that $\int_0^\infty t e^{-t} dt = 1$.

On the other hand, we have

$$\begin{aligned}
&\int_0^{2\pi} \int_0^{\delta r} (1 - D_r(u,\alpha))^{n-2} u du d\alpha \geq \\
&\int_0^{2\pi} \int_0^{\delta r} (1 - (4 + \epsilon)urF(\alpha))^{n-2} u du d\alpha \\
&\geq \int_0^{2\pi} \int_0^{\delta r} e^{-(4+2\epsilon)nurF(\alpha)} u du d\alpha \\
&= \frac{1+o(1)}{(4+2\epsilon)^2 n^2 r^2} \int_0^{2\pi} \frac{1}{F(\alpha)^2} d\alpha,
\end{aligned}$$

where the second inequality follows from the fact that $\ln(1 - (4 + \epsilon)urF(\alpha)) = -(4 + \epsilon)urF(\alpha) + O(u^2r^2)$, so that (provided δ was chosen sufficiently small) $u \leq \delta r$ implies $(1 - (4 + \epsilon)urF(\alpha)) \geq e^{-(4+2\epsilon)urF(\alpha)}$. The last line follows by previous computations. Now, notice that

$$\frac{\pi r^2 e^{-(4-\epsilon)\delta r^2 n}}{r^{-2}n^{-2}} = \pi (nr^2)^2 e^{-(4-\epsilon)\delta nr^2} = o(1),$$

as nr^2 tends to infinity. So indeed, the second term on the last line of (7) is negligibly small compared to the first. Moreover,

$$\int_0^{2\pi} \int_0^{\delta r} (1 - D_r(u, \alpha))^{n-2} u du d\alpha = \frac{1 + o(1)}{16n^2 r^2} 8 \int_{-\frac{\pi}{4}}^0 F(\alpha)^{-2} d\alpha.$$

In other words,

$$\mathbb{E}Z = \frac{1 + o(1)}{4r^2} \int_{-\frac{\pi}{4}}^0 F(\alpha)^{-2} d\alpha.$$

So it remains to determine $\int_{-\frac{\pi}{4}}^0 F(\alpha)^{-2} d\alpha$. For $r \leq \frac{1}{2}$ this equals $\frac{\pi}{4}$, which gives the result. Thus, assume now that $r \in (\frac{1}{2}, \frac{1}{2}\sqrt{2})$. Notice that

$$\begin{aligned} \int_{-\frac{\pi}{4}}^{-\frac{\beta}{2}} F(\alpha)^{-2} d\alpha &= \sin\left(\frac{\beta}{2}\right)^{-2} \int_{-\frac{\pi}{4}}^{-\frac{\beta}{2}} (\cos(\alpha) - \sin(\alpha))^{-2} d\alpha \\ &= \sin\left(\frac{\beta}{2}\right)^{-2} \left[\frac{\cos(\alpha)}{\cos(\alpha) - \sin(\alpha)} \right]_{-\frac{\pi}{4}}^{-\frac{\beta}{2}} \\ &= \sin\left(\frac{\beta}{2}\right)^{-2} \left(\frac{\cos(\frac{\beta}{2})}{\cos(\frac{\beta}{2}) + \sin(\frac{\beta}{2})} - \frac{1}{2} \right). \end{aligned}$$

For convenience, we let $c := (\cos(\frac{\beta}{2}) - \sin(\frac{\beta}{2}))^{-1} = (2 - \frac{1}{2r^2})^{-\frac{1}{2}}$. We can now write

$$\begin{aligned} \int_{-\frac{\beta}{2}}^0 (F(\alpha))^{-2} d\alpha &= \int_{-\frac{\beta}{2}}^0 (1 - (\cos(\frac{\beta}{2}) - \sin(\frac{\beta}{2})) \cos(\alpha))^{-2} d\alpha \\ &= c^2 \int_{-\frac{\beta}{2}}^0 (c - \cos(\alpha))^{-2} d\alpha \\ &= c^2 \left[\frac{2 \tan(\frac{\alpha}{2})}{(c^2 - 1)((c+1) \tan(\frac{\alpha}{2})^2 + c - 1)} + \frac{2c \arctan\left(\sqrt{\frac{c+1}{c-1}} \tan(\frac{\alpha}{2})\right)}{(c^2 - 1)^{\frac{3}{2}}} \right]_{-\frac{\beta}{2}}^0 \\ &= \frac{c^2}{4(c^2 - 1)} \left(\frac{2 \tan(\frac{\beta}{4})}{(c+1) \tan(\frac{\beta}{4})^2 + c - 1} + \frac{2c \arctan\left(\sqrt{\frac{c+1}{c-1}} \tan(\frac{\beta}{4})\right)}{\sqrt{c^2 - 1}} \right) \\ &= \frac{1}{\sin(\beta)} \left(\frac{2(\cos(\frac{\beta}{2}) - \sin(\frac{\beta}{2})) \tan(\frac{\beta}{4})}{(1 - \cos(\frac{\beta}{2}) + \sin(\frac{\beta}{2})) \tan(\frac{\beta}{4})^2 + 1 + \cos(\frac{\beta}{2}) - \sin(\frac{\beta}{2})} \right. \\ &\quad \left. + \frac{2}{\sqrt{\sin(\beta)}} \arctan\left(\sqrt{\frac{(1 - \cos(\frac{\beta}{2}) + \sin(\frac{\beta}{2}))}{(1 + \cos(\frac{\beta}{2}) - \sin(\frac{\beta}{2}))}} \tan(\frac{\beta}{4})\right) \right). \end{aligned}$$

The statement follows. \square

Proof of Lemma 12: Let us again set $\mathcal{P} := \binom{[n]}{2}$. For $P = \{i, j\} \in \mathcal{P}$, denote by $J(P)$ the indicator variable of the event that $\{X_i, X_j\}$ is a bad pair and set

$$p_{ij} = \mathbb{E}J(\{i, j\}) = \mathbb{P}(\{X_i, X_j\} \text{ is a bad pair}).$$

For $\{i, j\}, \{k, l\} \in \mathcal{P}$ let us also set

$$p_{ij,kl} := \mathbb{E}J(\{i, j\})J(\{k, l\}) = \mathbb{P}(\{X_i, X_j\}, \{X_k, X_l\} \text{ are both bad pairs}).$$

Notice that

$$\begin{aligned} \text{Var}(Z) &= \sum_{P_1, P_2 \in \mathcal{P}} \mathbb{E}J(P_1)J(P_2) - \mathbb{E}J(P_1)\mathbb{E}J(P_2) \\ &= \sum_{\substack{P_1, P_2 \in \mathcal{P}, \\ |P_1 \cap P_2|=2}} (\mathbb{E}J(P_1)J(P_2) - \mathbb{E}J(P_1)\mathbb{E}J(P_2)) \\ &\quad + \sum_{\substack{P_1, P_2 \in \mathcal{P}, \\ |P_1 \cap P_2|=1}} (\mathbb{E}J(P_1)J(P_2) - \mathbb{E}J(P_1)\mathbb{E}J(P_2)) \\ &\quad + \sum_{\substack{P_1, P_2 \in \mathcal{P}, \\ |P_1 \cap P_2|=0}} (\mathbb{E}J(P_1)J(P_2) - \mathbb{E}J(P_1)\mathbb{E}J(P_2)) \\ &= \binom{n}{2}(p_{12} - p_{12}^2) + \binom{n}{2}(n-2)(p_{12,13} - p_{12}^2) + \binom{n}{2}\binom{n-2}{2}(p_{12,34} - p_{12}^2). \end{aligned}$$

Observe that $\binom{n}{2}(p_{12} - p_{12}^2) \leq \mathbb{E}Z = o(r^{-4})$ by Lemma 11. Let us now consider $p_{12,13}$. For $x_1, x_2, x_3 \in \mathbb{R}^2$, denote by $\Phi(x_1, x_2, x_3)$ the probability that $\{X_1, X_2\}$ and $\{X_1, X_3\}$ are both bad pairs, given that $X_1 = x_1, X_2 = x_2, X_3 = x_3$. We have

$$\begin{aligned} p_{12,13} &= \int_{[0,1]^2} \int_{B(x_1, r)} \int_{B(x_1, r)} \Phi(x_1, x_2, x_3) dx_3 dx_2 dx_1 \\ &= 2 \int_{[0,1]^2} \int_{B(x_1, r)} \int_{\substack{B(x_1, r) \\ \|x_1 - x_3\| \leq \|x_1 - x_2\|}} \Phi(x_1, x_2, x_3) dx_3 dx_2 dx_1 \\ &\leq 2 \int_{[0,1]^2} \int_{B(x_1, r)} \int_{\substack{B(x_1, r) \\ \|x_1 - x_3\| \leq \|x_1 - x_2\|}} (1 - D_r(x_1, x_2))^{n-3} dx_3 dx_2 dx_1 \\ &= 2 \int_0^r \pi u^2 (1 - \alpha(u))^{n-3} 2\pi u du. \end{aligned}$$

Here $D_r(x, y)$ is as in the proof of Lemma 11. Computations analogous to those in the previous lemma now give that

$$\int_0^r (1 - \alpha(u))^{n-3} u^3 du = (1 + o(1)) \frac{1}{4^4 r^4 n^4} \int_0^\infty v^4 e^{-v} dv = \Theta(r^{-4} n^{-4}).$$

So we see that $\binom{n}{2}(n-2)(p_{12,13} - p_{12}^2) = O(n^{-1}r^{-4}) = o(r^{-4})$.

Let us now consider $p_{12,34}$, and denote by $\Psi(x_1, x_2, x_3, x_4)$ the probability that $\{X_1, X_2\}$ and $\{X_3, X_4\}$ are both bad pairs given that $X_1 = x_1, X_2 = x_2, X_3 = x_3, X_4 = x_4$. Let A be the set of all $(x_1, x_2, x_3, x_4) \in ([0, 1]^2)^4$ with $x_2 \in B(x_1, r), x_4 \in B(x_3, r)$. Denote by A_1 the set of all $(x_1, x_2, x_3, x_4) \in A$ with $\|x_1 - x_3\| < 100r$ and set $A_2 := A \setminus A_1$. We have

$$p_{12,34} = \int_A \Psi = \int_{A_1} \Psi + \int_{A_2} \Psi.$$

For $r \leq \frac{1}{4}$, the angle α is not relevant in $D_r(u, \alpha)$, so we will just write $D_r(u)$ here. If $(x_1, x_2, x_3, x_4) \in A_2$ then $B(x_1, r) \Delta B(x_2, r)$ and $B(x_3, r) \Delta B(x_4, r)$ are disjoint, and consequently

$$\begin{aligned} & (1 - \text{vol}((B(x_1, r) \Delta B(x_2, r)) \cup (B(x_3, r) \Delta B(x_4, r)))) \\ & \leq \\ & (1 - D_r(x_1, x_2))(1 - D_r(x_3, x_4)) \\ & = \\ & (1 - D_r(\|x_1 - x_2\|))(1 - D_r(\|x_3 - x_4\|)). \end{aligned}$$

So we can write

$$\begin{aligned} & \iiint_{A_2} \Psi(x_1, x_2, x_3, x_4) dx_1 dx_2 dx_3 dx_4 \\ & \leq \\ & \iiint_A (1 - D_r(\|x_1 - x_2\|))^{n-4} (1 - D_r(\|x_3 - x_4\|))^{n-4} dx_1 dx_2 dx_3 dx_4 \\ & = \\ & \left(\int_0^r (1 - D_r(u))^{n-4} 2\pi u du \right)^2 \\ & = \\ & (1 + o(1)) \left(\frac{\pi}{8r^2 n^2} \right)^2 \\ & = \\ & (1 + o(1)) p_{12}^2, \end{aligned}$$

reusing computations from the proof of Lemma 11 in the last two steps. On the other hand,

$$\begin{aligned} & \int_{[0,1]^2} \int_{B(x_1, r)} \int_{B(x_1, 100r)} \int_{B(x_3, r)} \Psi(x_1, x_2, x_3, x_4) dx_4 dx_3 dx_2 dx_1 \\ & = \\ & 2 \int_{[0,1]^2} \int_{B(x_1, r)} \int_{B(x_1, 100r)} \int_{\substack{B(x_3, r) \\ \|x_3 - x_4\| < \|x_1 - x_2\|}} \Psi(x_1, x_2, x_3, x_4) dx_4 dx_3 dx_2 dx_1 \\ & \leq \\ & 2\pi(100)^2 r^2 \int_0^r \pi u^2 (1 - D_r(u))^{n-4} 2\pi u du \\ & = \\ & \Theta(r^{-2} n^{-4}). \end{aligned}$$

We see that

$$\binom{n}{2} \binom{n-2}{2} (p_{12,34} - p_{12}^2) = \binom{n}{2} \binom{n-2}{2} (\Theta(r^{-2}n^{-4}) + o(1)p_{12}^2) = o(r^{-4}).$$

This shows that $\text{Var}(Z) = o(r^{-4})$, as required. \square

It now remains to prove Theorem 5 for fixed $r \in (0, \frac{1}{2}\sqrt{2})$. We will prove the following proposition.

Proposition 14 *For fixed $r \in (0, \frac{1}{2}\sqrt{2})$, the number Z of bad pairs satisfies*

$$Z \rightarrow \text{Po}(\mu(r)) \text{ in distribution.}$$

In particular,

$$\mathbb{P}(Z = 0) \rightarrow e^{-\mu(r)}.$$

As it turns out, the fixed r case has already been considered by Agarwal and Spencer [1] in a different setting. They proved Proposition 14 for $r < \frac{1}{10}$ and our proof is essentially the same as theirs, but we include it for completeness.

Proof of Proposition 14: Let us set $\rho = \rho(n) := \frac{\ln^2 n}{n}$. Let Y be the number of bad pairs X_i, X_j with $\|X_i - X_j\| < \rho$. Notice that

$$\mathbb{P}(Z \neq Y) \leq \mathbb{E}(Z - Y) = O\left(n^2 e^{\Omega(\ln^2 n)}\right) = o(1). \quad (8)$$

Here we have used that $D_r(u, \alpha) = \Theta(u)$. Recall that $(m)_k = m(m-1)\dots(m-k+1)$. We shall show that, for all k ,

$$\mathbb{E}(Y)_k = (1 + o(1))\mu(r)^k. \quad (9)$$

This will prove that Y — and hence also Z — is approximately $\text{Po}(\mu(r))$ -distributed, as all the moments of Y tend to the corresponding moments of the $\text{Po}(\mu(r))$, and the result will follow. This method is sometimes called *Brunn's sieve*, see for instance [2]. We shall proceed by induction on k . The case $k = 1$ has already been taken care of by Lemma 11 together with (8), so let us assume that (9) holds for $k - 1$, with $k \geq 2$. If $\mathcal{P} = \binom{\{X_1, \dots, X_n\}}{2}$ denotes all pairs of nodes and for $P \in \mathcal{P}$ we denote by $J(P)$ the event that P is a bad pair and the points of the pair are at distance $< \rho$, then

$$\mathbb{E}(Y)_k = \sum_{P_1 \in \mathcal{P}} \sum_{P_2 \in \mathcal{P} \setminus \{P_1\}} \dots \sum_{P_k \in \mathcal{P} \setminus \{P_1, \dots, P_{k-1}\}} \mathbb{P}(J(P_1), \dots, J(P_k)). \quad (10)$$

First notice that the contribution by terms with $P_i \cap P_j \neq \emptyset$ for some $i \neq j$ is small:

$$\begin{aligned}
& \sum_{P_1 \in \mathcal{P}} \sum_{P_2 \in \mathcal{P} \setminus \{P_1\}} \cdots \sum_{\substack{P_k \in \mathcal{P} \setminus \{P_1, \dots, P_{k-1}\} \\ |P_{k-1} \cap P_k|=1}} \mathbb{P}(J(P_1), \dots, J(P_k)) \\
& \leq \\
& \sum_{P_1 \in \mathcal{P}} \sum_{P_2 \in \mathcal{P} \setminus \{P_1\}} \cdots \sum_{\substack{P_k \in \mathcal{P} \setminus \{P_1, \dots, P_{k-1}\} \\ |P_{k-1} \cap P_k|=1}} \mathbb{P}(J(P_1), \dots, J(P_{k-1})) \pi \left(\frac{\ln^2 n}{n} \right)^2 \\
& \leq \\
& \sum_{P_1 \in \mathcal{P}} \sum_{P_2 \in \mathcal{P} \setminus \{P_1\}} \cdots \sum_{P_{k-1} \in \mathcal{P} \setminus \{P_1, \dots, P_{k-2}\}} \mathbb{P}(J(P_1), \dots, J(P_{k-1})) n \pi \left(\frac{\ln^2 n}{n} \right)^2 \\
& = \\
& (1 + o(1)) \mu(r)^{k-1} n \pi \left(\frac{\ln^2 n}{n} \right)^2 \\
& = \\
& o(1).
\end{aligned}$$

Here we have used the induction hypothesis. For $i = 1, \dots, k$ let us set $A(i) := \bigcap_{j=1}^i J(\{X_{2j-1}, X_{2j}\})$. By the previous we have

$$\begin{aligned}
\mathbb{E}(Y)_k &= \binom{n}{2} \binom{n-2}{2} \cdots \binom{n-2(k-1)}{2} \mathbb{P}(A(k)) + o(1) \\
&= (1 + o(1)) n^{2k} 2^{-k} \mathbb{P}(A(k)) + o(1).
\end{aligned}$$

Next, for $\epsilon > 0$ fixed,

$$\begin{aligned}
& n^{2k} 2^{-k} \mathbb{P} \left(A(k) \text{ and } \|X_{2i} - X_{2j}\| < n^{-\frac{1}{2}-\epsilon} \text{ for some } 1 \leq i < j \leq k \right) \\
& \leq \\
& n^{2k} 2^{-k} \binom{k}{2} \mathbb{P}(A(k-1)) \pi^2 \left(n^{-\frac{1}{2}-\epsilon} \right)^2 \left(n^{-\frac{1}{2}-\epsilon} + \rho \right)^2 \\
& = \\
& \binom{k}{2} (1 + o(1)) \mu(r)^{k-1} \pi^2 n^{-2-4\epsilon+o(1)} = o(1).
\end{aligned}$$

Consequently, we also have

$$\mathbb{E}(Y)_k = (1 + o(1)) n^{2k} 2^{-k} \mathbb{P}(B(k)) + o(1), \quad (11)$$

where $B(i)$, for $i \in \{1, \dots, k\}$, denotes the event that $A(i)$ holds and $\|X_{2j} - X_{2j'}\| > n^{-\frac{1}{2}-\epsilon}$ for every $j, j' \in \{1, 2, \dots, i\}$ with $j < j'$. For $x_1, \dots, x_{2k} \in [0, 1]^2$, let us set

$$D_r(x_1, \dots, x_{2k}) = \text{vol} \left(\bigcup_{i=1}^k (B(x_{2i-1}, r) \Delta B(x_{2i}, r)) \right)$$

We now claim that if $\|x_{2i-1} - x_{2i}\| < \frac{\ln^2 n}{n}$ for every $i \in \{1, 2, \dots, k\}$ and $\|x_{2i} - x_{2j}\| > n^{-\frac{1}{2}-\epsilon}$ for all $i, j \in \{1, 2, \dots, k\}$ with $i < j$, then

$$D_r(x_1, \dots, x_{2k}) = \sum_{i=1}^k D_r(x_{2i-1}, x_{2i}) + o(n^{-1}). \quad (12)$$

To see this consider $C = (B(x_1, r) \Delta B(x_2, r)) \cap (B(x_3, r) \Delta B(x_4, r))$ under the assumptions that $\|x_1 - x_2\|, \|x_3 - x_4\| < \rho$ and $\|x_2 - x_4\| = l \geq n^{-\frac{1}{2}-\epsilon}$. Then C is contained in the intersection of the two annuli $A_2 := \{y : r < \|y - x_2\| < r + \rho\}$ and $A_4 := \{y : r < \|y - x_4\| < r + \rho\}$, see figure 9 below. We will use the bound $\text{vol}(A_2 \cap A_4) \leq 2\frac{\alpha_2}{2\pi} \text{vol}(A_2)$

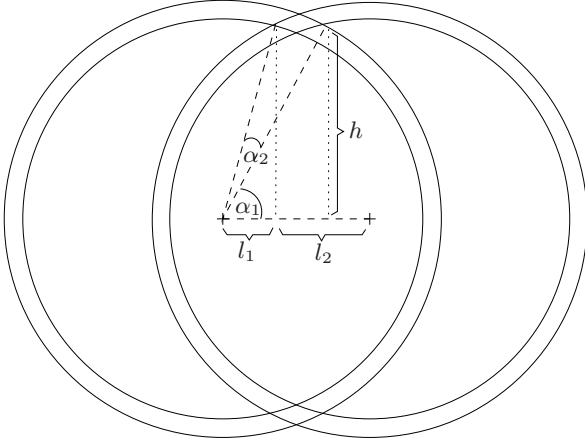

Figure 9: Bounding $\text{vol}(A_2 \cap A_3)$.

with α_1, α_2 as shown in figure 9. Now, the angles α_1, α_2 satisfy

$$\begin{aligned} \cos(\alpha_1) &= \frac{l_2}{r+\rho}, & \cos(\alpha_1 + \alpha_2) &= \frac{l_1}{r}, \\ \sin(\alpha_1) &= \frac{h}{r+\rho}, & \sin(\alpha_1 + \alpha_2) &= \frac{h}{r}. \end{aligned}$$

where h, l_1, l_2 are as in figure 9. In particular,

$$l = l_1 + l_2, \quad h^2 = r^2 - l_1^2 = (r + \rho)^2 - l_2^2. \quad (13)$$

Notice that l_1 may be negative (this can happen for small l), but this does not pose any limitation for our computations. First, assume that

$l_2 \geq \frac{1}{2}r$. The Taylor expansion of $\sin(x)$ around $x = \alpha_1$ gives

$$\frac{\rho h}{r(r+\rho)} = \sin(\alpha_1 + \alpha_2) - \sin(\alpha_1) = \cos(\alpha_1)\alpha_2 + O(\alpha_2^2) = \frac{l_2}{r+\rho}\alpha_2 + O(\alpha_2^2).$$

Since $\frac{1}{2}r \leq l_2 \leq r + \rho$ and $h \leq r$, we see that in this case we must have $\alpha_2 = O(\rho) = O(n^{-1+o(1)})$.

Now suppose that $l_2 \leq \frac{1}{2}r$. The Taylor expansion of $\cos(x)$ around $x = \alpha_1$ gives

$$\begin{aligned} \frac{l_1}{r} - \frac{l_2}{r+\rho} &= \frac{\rho l_1 - r(l_2 - l_1)}{r(r+\rho)} = \cos(\alpha_1 + \alpha_2) - \cos(\alpha_1) \\ &= -\sin(\alpha_1)\alpha_2 + O(\alpha_2^2) \\ &= -\frac{h}{r+\rho}\alpha_2 + O(\alpha_2^2). \end{aligned}$$

Observe that $h = \sqrt{(r+\rho)^2 - l_2^2} \geq r\frac{1}{2}\sqrt{3}$ and that, by equations (13),

$$l(l_2 - l_1) = l_2^2 - l_1^2 = (r+\rho)^2 - r^2 = 2\rho r + \rho^2.$$

Hence, $l_2 - l_1 = O(\frac{\rho}{l}) = O(n^{-\frac{1}{2} + \epsilon + o(1)})$, since $l \geq n^{-\frac{1}{2} - \epsilon}$. Thus this time we have $\alpha_2 = O(n^{-\frac{1}{2} + \epsilon + o(1)})$. Consequently, $\text{vol}(A_2 \cap A_3) \leq \frac{\alpha_2}{\pi} \text{vol}(A_2) = O(n^{-\frac{1}{2} + \epsilon + o(1)}\rho) = O(n^{-\frac{3}{2} + \epsilon + o(1)})$. This proves (12).

Now let $x_2, x_4, \dots, x_{2k} \in [0, 1]^2$ be such that $\|x_{2j} - x_{2i}\| > n^{-\frac{1}{2} - \epsilon}$ for all $i, j \in \{1, 2, \dots, k\}$ with $i < j$. Then

$$\begin{aligned} &\mathbb{P}(B(k) | X_2 = x_2, \dots, X_{2k} = x_{2k}) \\ &= \int_{B(x_2, \rho)} \dots \int_{B(x_{2k}, \rho)} (1 - D_r(x_1, \dots, x_{2k}))^{n-2k} dx_1 dx_3 \dots dx_{2k-1} \\ &= \int_{B(x_2, \rho)} \dots \int_{B(x_{2k}, \rho)} (1 - \sum_{i=1}^k D_r(x_{2i-1}, x_{2i}) + o(n^{-1}))^{n-2k} dx_1 \dots dx_{2k} \\ &= \int_0^{2\pi} \int_0^\rho \dots \int_0^\rho \int_0^\rho (1 - \sum_{i=1}^k D_r(u_i, \alpha_i) + o(n^{-1}))^{n-2k} u_1 \dots u_k du_1 d\alpha_1 \dots du_k d\alpha_k \\ &= \end{aligned}$$

$$\begin{aligned}
& (1 + o(1)) \int_0^{2\pi} \int_0^\rho \dots \int_0^{2\pi} \int_0^\rho \exp[-(1 + o(1))] \\
& \sum_{i=1}^k nD_r(u_i, \alpha_i) + o(1) u_1 \dots u_k du_1 d\alpha_1 \dots du_k d\alpha_k \\
& = \\
& (1 + o(1)) \left(\int_0^{2\pi} \int_0^\rho \exp[-(1 + o(1)) \sum_{i=1}^k nD_r(u, \alpha) + o(1)] u du d\alpha \right)^k \\
& = \\
& (1 + o(1)) \left(\frac{2\mu(r)}{n^2} \right)^k,
\end{aligned}$$

where the last three lines follow by computations as in Lemma 11. Thus, setting $W := \{(x_2, x_4, \dots, x_{2k}) \in ([0, 1]^{2k}) : \|x_{2i} - x_{2j}\| > n^{-\frac{1}{2}-\epsilon} \text{ for all } 1 \leq i < j \leq k\}$, we also have

$$\begin{aligned}
\mathbb{P}(B(k)) &= \int \dots \int_W \mathbb{P}(B(k) | X_2 = x_2, \dots, X_{2k} = x_{2k}) dx_2 dx_4 \dots dx_{2k} \\
&= (1 + o(1)) \left(\frac{2\mu(r)}{n^2} \right)^k,
\end{aligned}$$

since the $2k$ -dimensional volume $\text{vol}(W)$ of W is $1 + o(1)$. Combining this with (11) gives the result. \square

4 Conclusion

We addressed in this paper, via the notion of identifying codes, the question of a location-detection system for a set of sensors whose communication area is modelled by disks. Therefore, we considered the class of unit disk graphs. We first extended a previous complexity result from the class of bipartite graphs to the class of planar bipartite unit disk graphs. Our second result concerns random unit disk graphs. We showed that, asymptotically almost surely, an identifying code does not exist for such a graph, if the radius r of the disks is such that $nr^2 \gg \frac{1}{n}$ and $r = o(1)$. For fixed $r > 0$, the probability that an identifying code exists is always bounded away from one, so that it does not seem to make a lot of sense to pursue this line of research further. In contrast, for the Erdős-Rényi model of random graphs, it has been shown that if p and $1 - p$ both are at least $\frac{4 \log \log n}{\log n}$, then an identifying code exists whp. [8]. Notice this includes all fixed $p \in (0, 1)$. Hence one can then — as the authors of [8] did — proceed to investigate the size of the *smallest* identifying code. In the case of random unit disk graphs an identifying code is only guaranteed when $nr^2 \ll \frac{1}{n}$, and in this case the only such code is the entire vertex set.

Of course, one might look for the size of a smallest identifying code in the other cases, if we condition on the event that such a code exists.

Another topic of research would be to slightly relax the definition of the code so that it always exists. For instance, a *location code* is the same as an identifying code, except that it does not need to identify the vertices belonging to the code. This notion could still be useful for real situations, and lead to interesting results.

References

- [1] A. Agarwal and J. Spencer. Undecidable statements and the zero-one law in random geometric graphs. Submitted, 2006.
- [2] N. Alon and J. Spencer. *The probabilistic method*. Wiley-Interscience Series in Discrete Mathematics and Optimization. Wiley-Interscience [John Wiley & Sons], New York, second edition, 2000. With an appendix on the life and work of Paul Erdős.
- [3] H. Breu and D. G. Kirkpatrick. Unit disk graph recognition is NP-hard. *Comput. Geom.*, 9(1-2):3–24, 1998.
- [4] K. Chakrabarty, S. S. Iyengar, H. Qi, and E. Cho. Coding theory framework for target location in distributed sensor networks. In *International Symposium on Information Technology: Coding and Computing*, pages 130–134. IEEE Computer Society, 2001.
- [5] I. Charon, O. Hudry, and A. Lobstein. Identifying and locating-dominating codes: NP-completeness results for directed graphs. *IEEE Trans. Inform. Theory*, 48(8):2192–2200, 2002.
- [6] I. Charon, O. Hudry, and A. Lobstein. Minimizing the size of an identifying or locating-dominating code in a graph is NP-hard. *Theoret. Comput. Sci.*, 290(3):2109–2120, 2003.
- [7] U. Fößmeier, G. Kant, and M. Kaufmann. 2-visibility drawings of plane graphs. In *Proceedings of Graph Drawing '96*, volume 1190 of *Lecture Notes in Comput. Sci.*, pages 155–168. Springer, Berlin, 1996.
- [8] A. Frieze, R. Martin, J. Moncel, M. Ruzinko, and C. Smyth. Codes identifying sets of vertices in random networks. Research Report Les Cahiers Leibniz 137, Laboratoire Leibniz, Grenoble, 2005.
- [9] B. Hofmann-Wellenhof, H. Lichtenegger, and J. Collins. *Global Positioning System: Theory and Practice*, 4th ed. Springer-Verlag, 1997.

- [10] M. G. Karpovsky, K. Chakrabarty, and L. B. Levitin. On a new class of codes for identifying vertices in graphs. *IEEE Trans. Inform. Theory*, 44(2):599–611, 1998.
- [11] D. Lichtenstein. Planar formulae and their uses. *SIAM J. Comput.*, 11(2):329–343, 1982.
- [12] S. Long, D. Aust, G. Abowd, and C. Atkeson. Rapid prototyping of mobile contextaware applications: The cyberguide case study. In *Proceedings of the 1996 conference on Human Factors in Computing Systems — CHI’96*, pages 97–107, 1996.
- [13] A. Papakostas and I. G. Tollis. Orthogonal drawings of high degree graphs with small area and few bends. In *Proceedings of 5th Workshop on Algorithms and Data Structures*, volume 1272 of *Lecture Notes in Comput. Sci.*, pages 354–367. Springer, Berlin, 1998.
- [14] M. D. Penrose. *Random Geometric Graphs*. Oxford University Press, Oxford, 2003.
- [15] N. Priyantha, A. Chakraborty, and H. Balakrishnan. The cricket location-support system. In *Proceedings of the Sixth Annual ACM International Conference on Mobile Computing and Networking*, pages 32–43, 2000.
- [16] S. Ray, D. Starobinski, A. Trachtenberg, and R. Ungrangsi. Robust location detection with sensor networks. *IEEE Journal on Selected Areas in Communications (Special Issue on Fundamental Performance Limits of Wireless Sensor Networks)*, 22(6):1016–1025, 2004.
- [17] S. Ray, R. Ungrangsi, F. De Pellegrini, A. Trachtenberg, and D. Starobinski. Robust location detection in emergency sensor networks. In *Proceedings of the 22nd Conference on Computer Communications, INFOCOM*, 2003.
- [18] R. Ungrangsi, A. Trachtenberg, and D. Starobinski. An implementation of indoor location detection systems based on identifying codes. In *Intelligence in Communication Systems, INTELLCOMM*, volume 3283 of *Lecture Notes in Computer Science*, pages 175–189. Springer, 2004.
- [19] R. Want, A. Hopper, V. Falcao, and J. Gibbons. The active badge location system. *ACM Transactions on Information Systems*, 10:91–102, 1992.